

# ***INSTALLATION INSTRUCTIONS***

**MODEL NO. 55342**

**APPLICATION:** 2006 Dodge Ram 1500 P/U (Excludes Mega Cab)

**NOTE:** This bracket kit is to be used with the 70580 Bed Rail Kit.

### **COMPLETE PARTS LIST**

Part	Description	Quantity
1.	3171-01 Lt. Front Bracket	(1)
2.	3173-04 Lt. Front Clamp Bracket	(1)
3.	3175-06 Rt. Front Bracket	(1)
4.	3177-08 Rt. Front Clamp Bracket	(1)
5.	2029-04 Rear Mounting Bracket	(1)
6.	2028-02 Rear Mounting Bracket	(1)
7.	3281-02 3/4 Spacer Plate	(4)
8.	2605-01 Spacer Plate	(4)
9.	2499-03 1/2-13 x 5-1/2 U-Bolt	(2)
10.	3730-05 1/2 Conical Washer	(8)

Part	Description	Quantity
11.	4034-05 1/2-13 Nylon Hex Nut	(8)
12.	4308-03 1/2-13 x 5 Carriage Bolt	(4)
13.	4434-06 5/8-11 x 3 Hex Bolt	(2)
14.	2883-03 5/8-11 x 5-1/2 Hex Bolt	(2)
15.	1732-09 5/8 Wide Flatwasher	(4)
16.	1843-03 5/8 Standard Flatwasher	(2)
17.	1881-03 5/8 Lockwasher	(4)
18.	1863-03 5/8-11 Hex Nut	(2)
19.	1393-01 2-3/8" Tube Spacer	(2)

**CAUTION:** Do not install mounting rails over plastic bed liners. Plastic bed liners must be cut out of the way. Rails may be installed on spray in liners.  
**NOTE:** Consult spray liner installer for recommended curing time.

1. On the inside of the left vehicle frame is a wiring harness that is held in place with plastic clips. This section of wiring harness must be moved aside by removing plastic clips from frame. This will allow the hitch parts to be positioned correctly on frame.

1a. Place the two bed rails across the truck bed between the wheel wells. Position the 5th wheel uprights on to the bed rails so that the tabs in the base of each upright will fit into the slots in the ends of the bed rails. Secure the uprights in place with the rail hitch pins and hair pins supplied with the 5th wheel installation kit. Securely attach 5th wheel cross member to uprights.

2. Position the bed rail assembly in truck bed as shown on the Illustration 1. Be sure bed rails are parallel by measuring diagonally as shown on Illustration 1a.

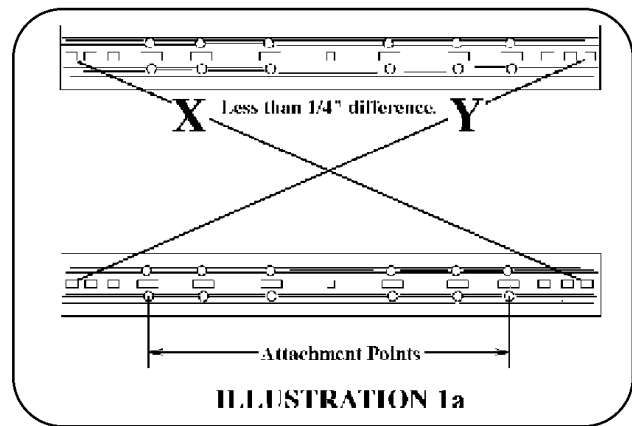
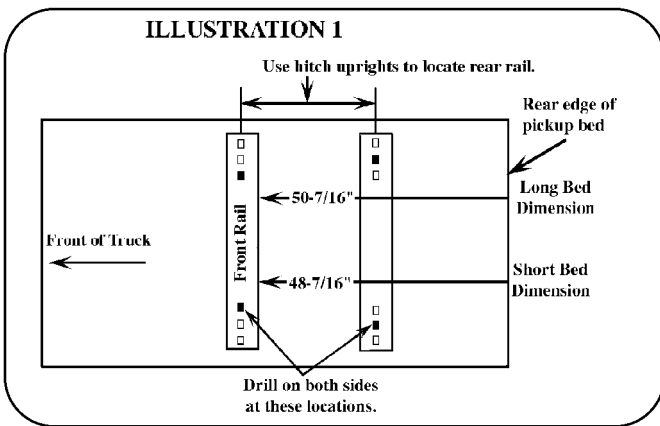
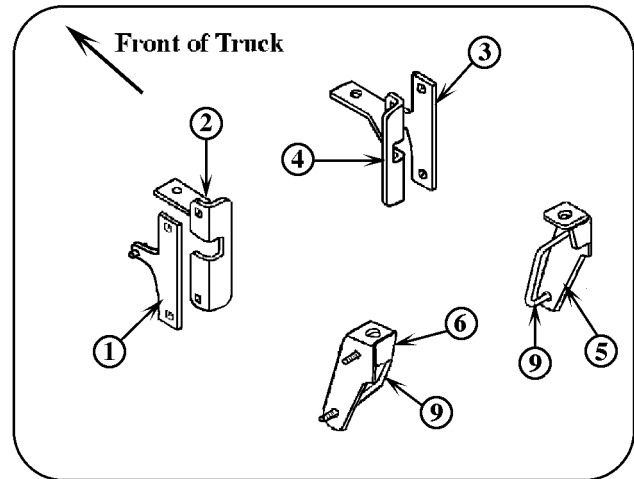

3. Mark two attachment points on the truck bed using the slots in the front base rail as indicated on Illustration 1.
- NOTE:** Mark to the inner edge of the forward slots. Do not mark rear bed rail points at this time. Check below the bed before drilling holes to see that all wiring, brake lines or other obstructions are moved out of the way and will not be contacted by the drill. Drill a 1/4" diameter pilot holes down through the bed and hat section at the previously marked points. Be certain that the holes are drilled in correct location. They must also be drilled through the under bed hat section.

4. There are no existing holes in the frame so you will be required to drill the hole in the side of each truck frame. See Illustration 2 for hole location information. Be sure hole is placed exactly as shown and drilled to the correct diameter. Position the left and right front outer brackets #1 and #3 against their respective truck frames so that the pin in each bracket aligns with the previously drilled hole in the side of each vehicle frame.

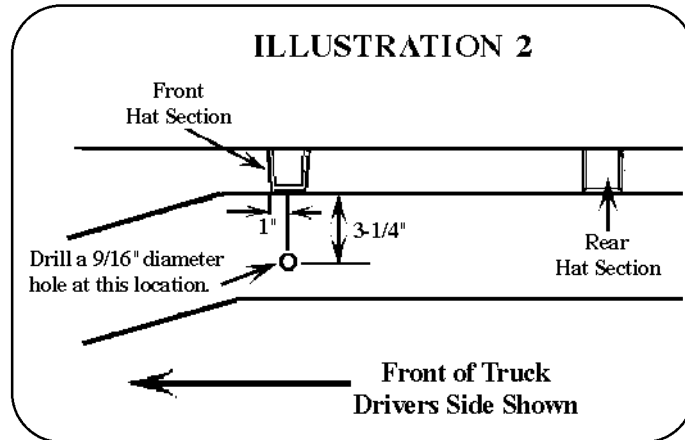

5. Bolt the left and right front outer brackets #1 and #3 to frame with the inner clamp brackets #2 and #4. Take care when positioning the left inner bracket #2 so that the slot in bracket fits over the steel brake line. See Illustration 3 and 3a. Use the carriage bolts #12 at both bracket attachments. Slide bracket #2 rearward away from the gas tank so long bolt can be installed. Then slide bracket forward into position. The tab on the inner bracket should be against the bottom of the bed support hat section. The hole in the tab should be aligned with the previously drilled 1/4" pilot hole.

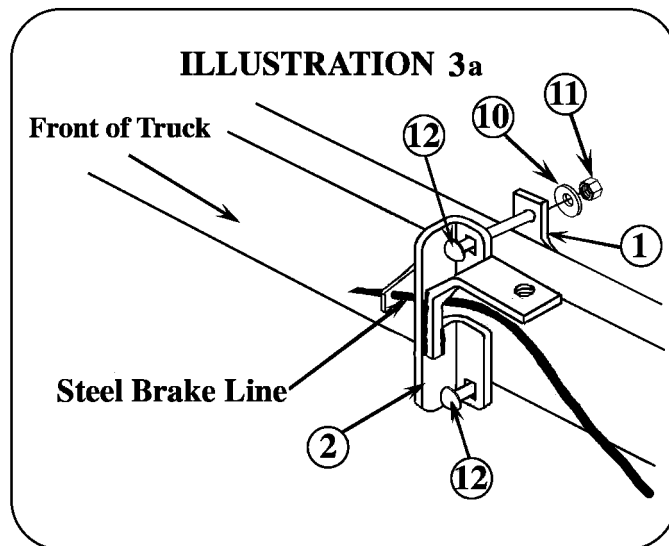
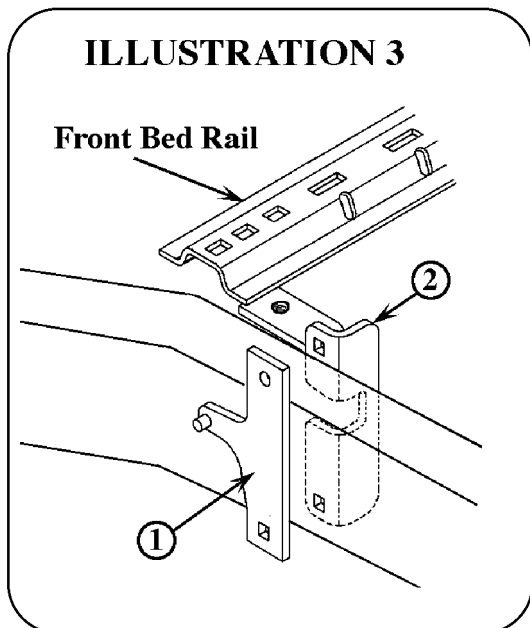

6. Position the bed rails in the bed so that the inner square 5/8" hole in the front rail is lined up over the previously drilled pilot holes. Double check that the pilot holes line up with holes in bed rail and tab on frame bracket under the bed.. Move bed rails away from pilot holes and drill a 3/4" hole down through truck bed at each of the previously drilled pilot holes. The 3/4" hole will give some tolerance to get bolt down into the bracket hole. **Use caution when drilling so that drill does not make contact with the installed brackets or fuel tank under the bed.**

**NOTE:** For alternative installation procedures refer to the last page of this document.

7. Place a 3/4" thick spacer plate #7 under ends of each bed rail, in line with the drilled holes, as shown on Illustration 4. If the bed corrugation above the mounting bracket at the drilled hole is UP, leaving a space above the bracket, place a spacer plate #8 in this location as shown on Illustration 5. If the corrugation is DOWN, at this location, place a spacer plate #8 in the bed, under the base rail as shown on Illustration 5a.

8. Slide tube spacers #19 into the forward bed support hat section from the open end in each wheel well.

**NOTE:** On some applications a small sheet metal flange may appear to obstruct placement of the spacer tube. This flange can be modified to gain access to the hat section. See detail for this procedure on Illustration 6.

9. On left side of truck align the tube spacer with drilled hole and drop the long 5/8" bolts #14 with the 5/8 flatwashers #15 and 5/8 lockwasher #17 down through all parts and mounting brackets. See Illustration 6a. Thread bolt into tapped plate on left front inner bracket #2. Repeat procedure on right side of front bed rail using 5/8 flatwasher #15, and lockwasher #17. See Illustration 6b. Tighten the 5/8" bolts to 125-160 ft. lbs. torque.

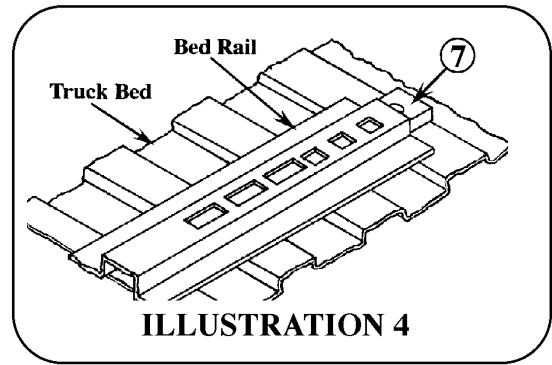

**ILLUSTRATION 4**

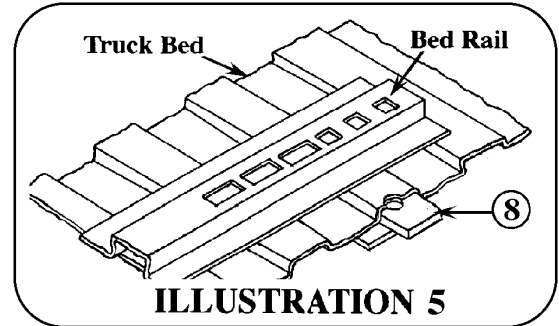

**ILLUSTRATION 5**

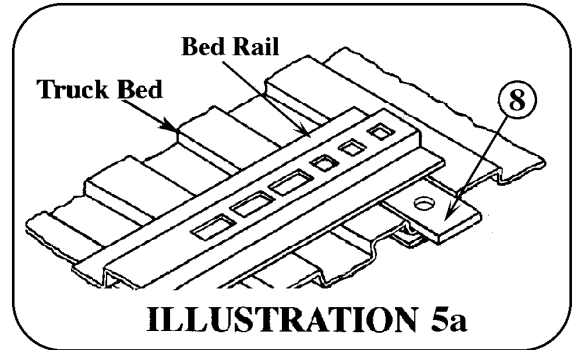

**ILLUSTRATION 5a**

**ILLUSTRATION 6**

Make two 3/4" cuts in sheet metal flange s shown. Bend flap outward and up to insert tube spacer. Bend flap down after installation is complete. Cut areas my be covered with paint or undercoating

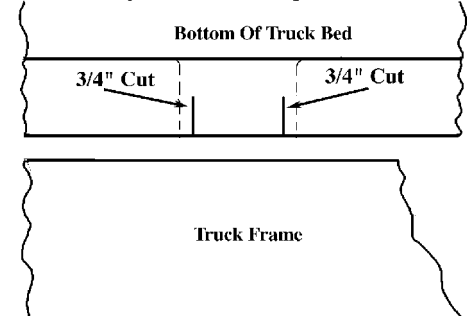

10. Mark the rear hole locations using the rear bed rails as shown on Illustration 1. Drill a 5/8" hole down through bed using the center 5/8" hole in each end of rear bed rail as a guide as shown on Illustration 1.
11. Place spacer plates under bed rails as described in Step 6. Place the 5/8 x 3 hex bolts #13 with wide 5/8 flatwashers #15 and 5/8 lockwashers #17 down through bed rail, spacer plates and truck bed at drilled holes.
12. Place the left rear mounting bracket #5 against the outside surface of the right frame and the right rear mounting bracket #6 against the outside surface of the left frame with the mounting tabs positioned over the truck frame rails in line with the previously installed 5/8" bolts. See Illustration 8 which shows the left frame. Bolt the brackets loosely in place at these bolts with 5/8 flatwashers #16, 5/8 lockwashers #17 and 5/8 hex nuts #18.
13. Secure the rear mounting bracket #5 and #6 to the left and right truck frame with the U-Bolts #9 as shown on Illustration 8 and 9.
14. Tighten all 1/2" bolts to 75 ft. lbs. torque and all 5/8" bolts to 125-160 ft. lbs. torque.

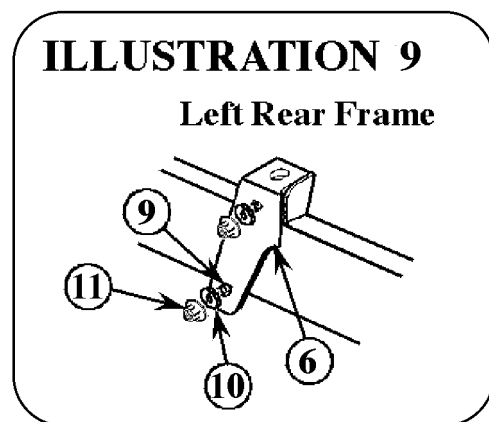
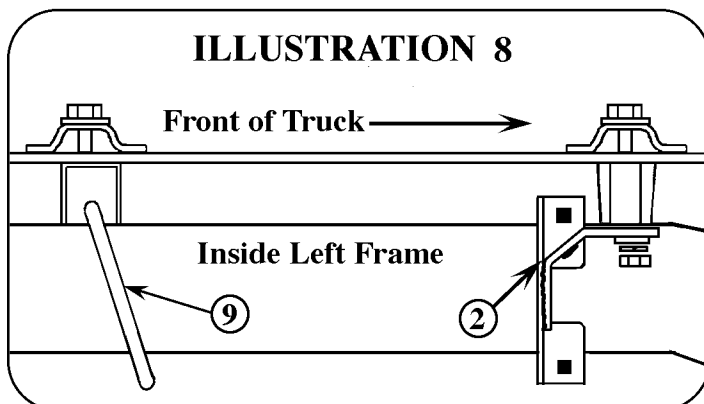
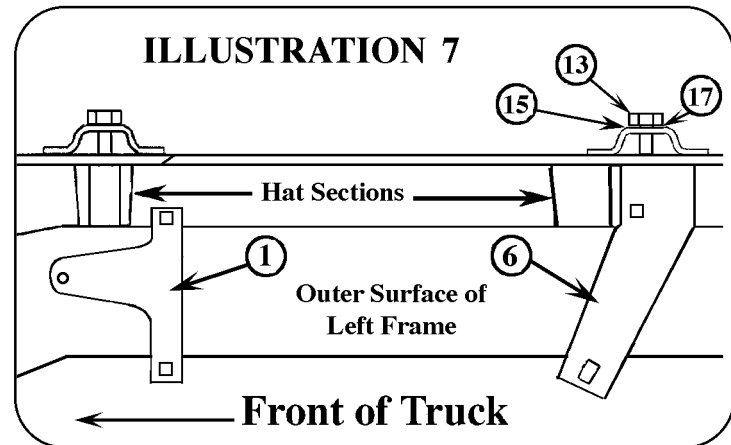
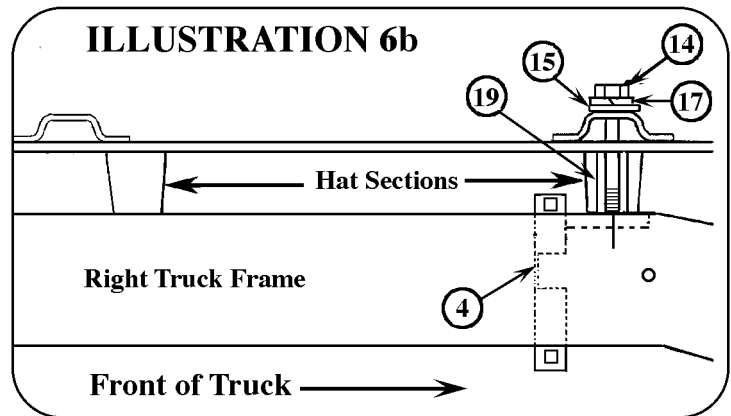
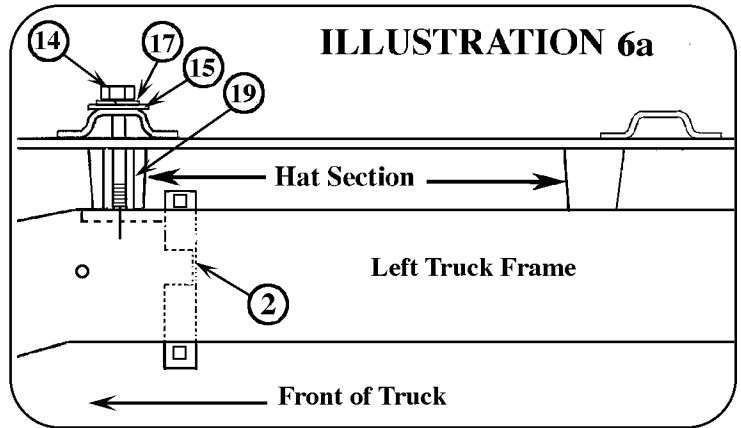

## **Alternative Installation Procedure**

**BE SURE TO ADVISE CUSTOMER ABOUT THE LARGE HOLES THAT WILL BE CUT INTO BED BEFORE BEGINNING THIS INSTALLATION.**

1. Cut a 1-1/4" hole down through the bed at pilot hole location. This hole must only be cut through bed of truck, not through bottom of the hat section under the bed.
2. Drill a 5/8" hole through bottom of the hat section under the bed at the previously drilled pilot hole.
3. Remove the wire handle from spacer tube #9. Drop the spacer tube down through the hole in bed so that it will rest on the under bed hat section in line with the previously drilled 5/8" diameter hole.
4. With the front base rail in place, drop one of the 5/8 x 5-1/2" hex bolts #14 down through the base rail, tube spacer #19 and frame bracket tab. Bolt securely in place at this location.
5. Repeat procedure on other end of front base rail.
6. Continue with Step 7 on Main Instructions.

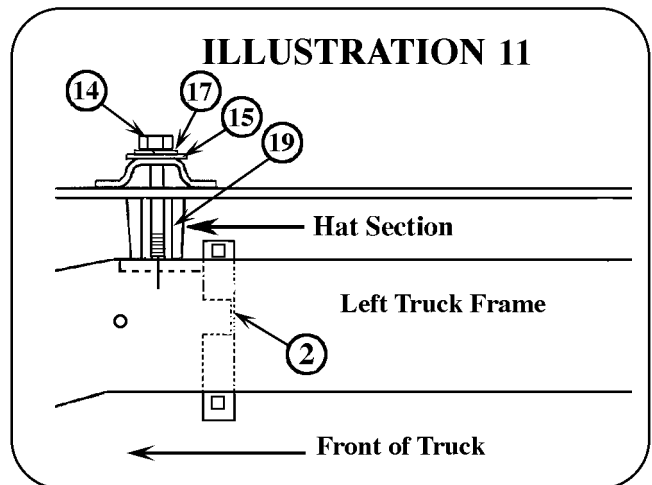
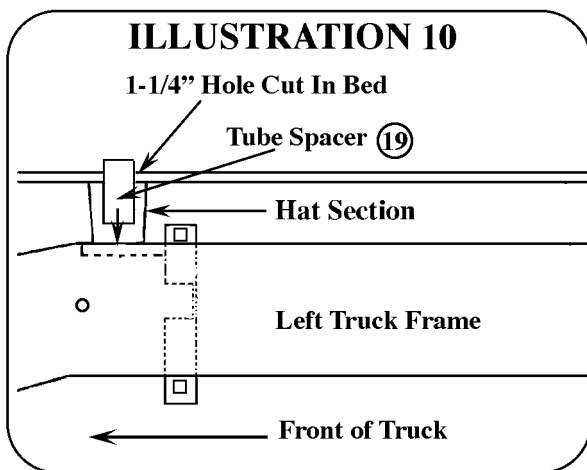

For information regarding this product, or our warranty, contact your dealer or write to:  
"CUSTOMER SERVICE MANAGER" P.O. Box 850, Lodi, CA 95241

This product complies with regulation V-5, C.S.A Standard D-264 and safety requirements for connecting devices and towing systems of the State of New York