



**B&W Trailer Hitches**  
 1216 HWY 224 / PO Box 186  
 Humboldt, KS 66748  
 620.473.3664  
 800.248.6564  
 Fax:620.473.3766

hitches@turnoverball.com  
 www.turnoverball.com

**Turnover Ball™  
 Gooseneck Hitch  
 Installation Instructions**

**Model 1000R**

**Chevrolet & GMC (1988 - 1998)**

1/2 3/4 & 1 Ton, Long Bed Trucks

**Chevrolet & GMC (1999 - 2000)**

3/4 & 1 Ton Heavy Duty Long Bed Trucks  
 (Old Body Style)

*Call or Email us for Installation Support*

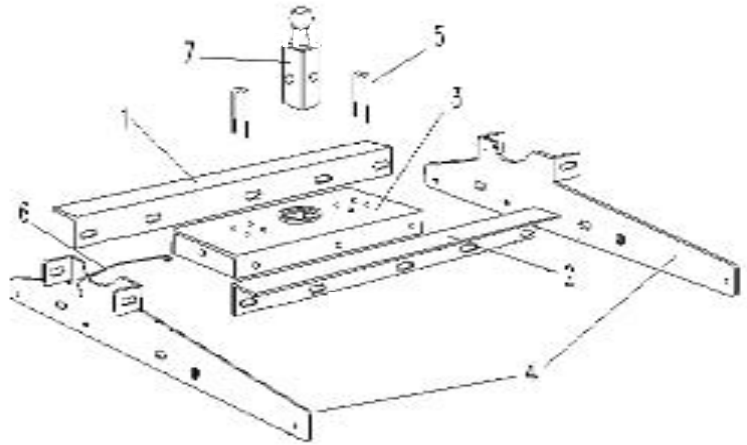

**BEFORE INSTALLING  
 OVERHEAD LIFTING DEVICE**

An overhead-lifting device, such as chain falls, engine hoist, or cable come-a-long, can be used to lift the center section of the hitch in place. Lower a loop of rope or chain through the 4" hole in the truck bed floor and attach it to the latch pin in the round hitch receiver tube in the center section. Use the lifting device to raise the center section until the round hitch receiver tube that protrudes from the center section fits in the 4" hole in the truck bed floor. Maintaining upward pressure may facilitate fastening the crossmember to the center section, especially if the truck bed floor has been distorted downward from heavy use. If you use an overhead-lifting device, it should be disconnected before squaring the center section across the frame, installing the sideplates and torquing fasteners.

**Part List**

- 1 - Front Crossmember
- 2 - Rear Crossmember
- 3 - Center Section
- 4 - Sideplates (2)
- 5 - Safety Chain U-Bolts
- 6 - Latch Pin Handle
- 7 - Turnover Ball

**Hardware Kit**

- 14 ea. - 1/2" X 1 1/2" bolts
- 28 ea. - 1/2" flat washers
- 14 ea. - 1/2" lock washers
- 14 ea. - 1/2" nuts

**Safety Chain Kit**

- 2 ea. - 1/2" U-bolts
- 4 ea. - 1/2" lock nuts
- 4 ea. - springs
- 1 ea. - 3/8"x3/4" bolt
- 1 eac. - 3/8" lock nut

**WARNING**

Most trucks have FUEL LINES and/or BRAKE LINES and/or ELECTRICAL WIRES located along the frame rails where B&W Turnover Ball hitches install. Carefully examine the location of fuel lines, brake lines and electrical wires BEFORE INSTALLATION. Be certain you will not damage fuel lines, brake lines or electrical wires when positioning hitch components, drilling holes, tightening fasteners, and lifting and lowering the truck bed. The fuel tank vent, located on top of the gas tank, can be easily damaged during the installation of the hitch components. Care must be taken when positioning the front crossmember and center section components.

**Warning**

On Short bed trucks, BEFORE INSTALLING THIS HITCH, check for adequate turning clearance between the front of all of your trailers and the truck cab.

**Warning**

DO NOT invert the ball in the socket when carrying heavy loads on 2 wheel drive trucks. The ball may hit the top of the differential. Remove the ball from the socket before loading. A plug for the socket is available from B & W.

# INSTALLATION

## STEP ONE

Begin by verifying and measuring the correct hole location in the truck bed floor. Measure from the back end (tail gate end) of the truck bed floor by hooking a tape measure over the back of the sheet metal and marking the floor at the **49 1/2"**. Center the measurement between the fender wheel wells. This location is critical to the correct installation of this hitch, so measure, mark and saw carefully. If the truck has a plastic bed liner, you may drill through both, but it is more difficult to accurately locate the midpoint between the fender wheel wells, and to be sure that the bed liner does not move while sawing the hole. Make a 4-inch hole at this location using a four inch hole saw, or by marking a 4 inch circle and cutting it out with a sabersaw equipped with a metal cutting blade.

## STEP TWO

Select the front cross member. This is the longer of the two cross members. With the horizontal side up and the slotted side facing the rear of the truck, position it across the top of the frame rails, between the bed and the frame, by pushing it through the opening in the wheel well. Place the rear cross member behind the first with the horizontal side up and the slotted side facing the front of the truck. With the two cross members approximately parallel, position them about 9" apart, equally spaced in front and behind the hole in the truck bed floor, with the ends extended 2" over the frame rails.

## STEP THREE

Install the side plates by aligning two of the lower holes in the side plate with existing holes in the truck frame rails and fasten into place using two 1/2"x 1 1/2" bolts with a flat washer on each side and a lock washer and nut on each. Hand tighten bolts. When installing the driver's side side plate, you may have to pull the brake line down to accommodate the bolts. Bolts should be inserted from the inside. Fasten the front cross member to the side plates using 1/2" x 1 1/2" bolts.

## STEP FOUR

With the latch pin mechanism on the driver's side, raise the center section of the hitch into position against the front cross member from beneath the truck. The round tube hitch receiver that protrudes from the center section must fit through the hole in the truck bed floor. Fasten the center section to the front cross member using three 1/2" x 1 1/2" bolts. Move the rear cross member into place against the center section and fasten using three 1/2" x 1 1/2" bolts. With the cross members, side plates and center section installed, torque all fasteners to 90- ft. lbs. In the following sequence: First torque the side plates to the frame. Second, torque the cross members to the side plates. Third, torque the center section to the cross members.

## STEP FIVE

To install the safety chain brackets, it is necessary to drill four 1/2" holes through the truck bed floor. Drill the holes from beneath the truck, through the 4 holes nearest the round hitch receiver tube in the center section. This will locate the safety chain brackets in the valley section of the bed floor. Drop a U-bolt through each pair of holes from the topside of the truck bed floor. Place a spring and lock nut on each of the four legs and tighten the lock nuts until 1/4" of the thread extends through the lock nut.



## STEP SIX

Install the latch release handle by inserting the handgrip end of the handle rod from inside the center section through the hole in the endplate. Align the handle loop and the hole in the tab on the end of the latch pin assembly, putting the handle loop on the correct side of the tab and bolt together using the 3/8" x 3/4" bolt and lock nut. When properly attached, the center of the handle should be in line with the center of the pin assembly, and the bolt head should be on the loop side, and the nut on the tab side.



## STEP SEVEN

Retract the latch pin by pulling the handle out until it stops and then rotating to the lock out position. Place the turnover ball in the hitch receiver. Engage the latch pin by rotating the handle back to center. Be certain the latch pin passes through the holes in the turnover ball and fully engages through the hitch receiver. Repeat this process with the turnover ball in all eight positions. Grease the base of the turnover ball.