

# Installation Instructions

## GOOSENECK MOUNTING KIT

**Part Numbers:**

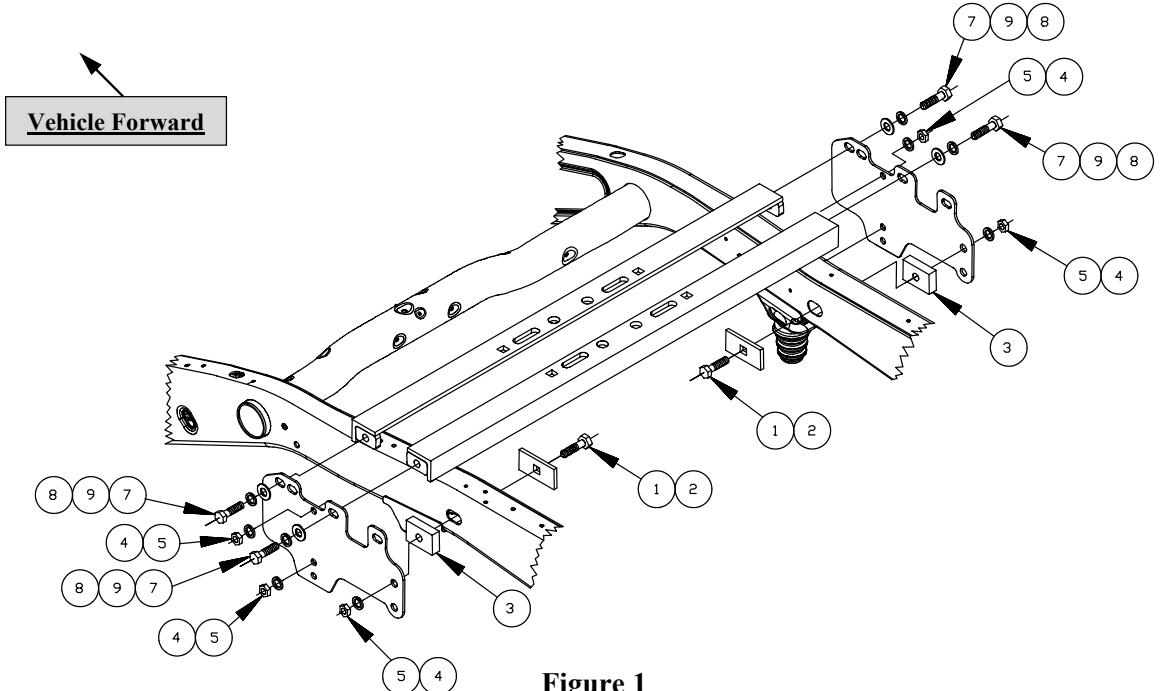
**4431**

Chevrolet/GMC 1500 Short & Long Bed  
2500 Light Duty Short Bed

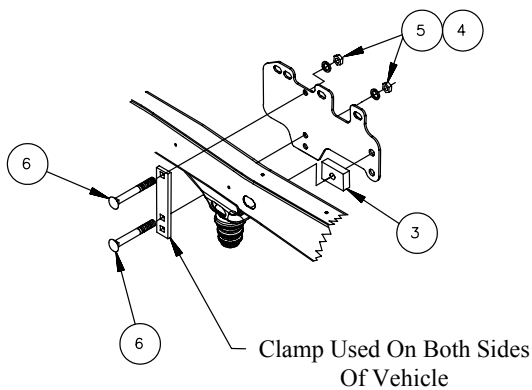
**Equipment Required:**

- Fastener Kit:** 4431F
- Wrenches:** 3/4, 15/16, 13mm
- Drill Bits:** 1/4"
- Other Tools:** 4" Hole-Saw, Drill

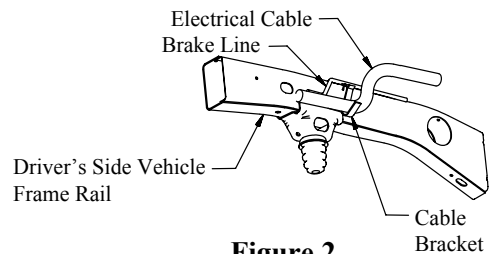
**WARNING:** Under no circumstances do we recommend exceeding the towing vehicle manufacturers recommended vehicle towing capacity.



**Figure 1**



**Clamp Installation**



**Figure 2**

1	Qty. (2)	Hex Bolt, 1/2-13 x 2.75 GR5	6	Qty. (4)	Carriage Bolt, 1/2 X-13 X 4.50 GR5
2	Qty. (2)	Block, 1/4 X 1.00 X 3.00	7	Qty. (4)	Hex Bolt, 5/8-11 X 1.50 GR5
3	Qty. (2)	Block, 5/8 X 1.00 X 2.00	8	Qty. (4)	Flat Washer, 5/8
4	Qty. (6)	Lock Washer, 1/2	9	Qty. (4)	Lock Washer, 5/8
5	Qty. (6)	Hex Nut, 1/2	10	Qty. (4)	Shims, 1/4 X 2.00 X 1.00

# Installation Instructions

Part Numbers:

Chevrolet/GMC 1500 Short & Long Bed  
2500 Light Duty Short Bed

**4431**

## NOTES:

- This rail kit can be used with a 6300, 8339, 9461 or 9463 head only.
- Always make sure the ball is fully locked before towing.
- Keep the flat sections of the ball and ball pocket well lubricated.
- Periodically re-torque all the hitch fasteners.
- Check ball, hitch coupler, safety chains and other connections for proper operation every time you tow.

## Warning:

- ❖ The tow vehicle manufacturers recommended towing capacities should UNDER NO CIRCUMSTANCES be exceeded.
- ❖ Check for adequate clearance between the gooseneck trailer and the rear of the cab and the rear of the truck box before installing hitch.
- ❖ All trucks have fuel lines, brake lines and electrical wiring located along the vehicle frame where the rail kit installs. Carefully examine the location of fuel lines, brake lines and electrical wires before installation and be certain not to damage these when positioning the hitch components. Be careful when drilling holes, cutting sheet metal and tightening fasteners as to not limit the integrity of these systems.

## Installation Instructions

1. Figure 2 shows a cable bracket which holds a brake line to the inside of the frame rail. Loosen this bracket from the top of the frame and move the brake line down about 1/2" so that it is not interfering with hitch cross members.
2. From underneath the passenger's side of vehicle remove or cut out the section of the heat shield that is located between the frame rails and the bed of the vehicle.

### 9461/9463 Hide-A-Goose Installation

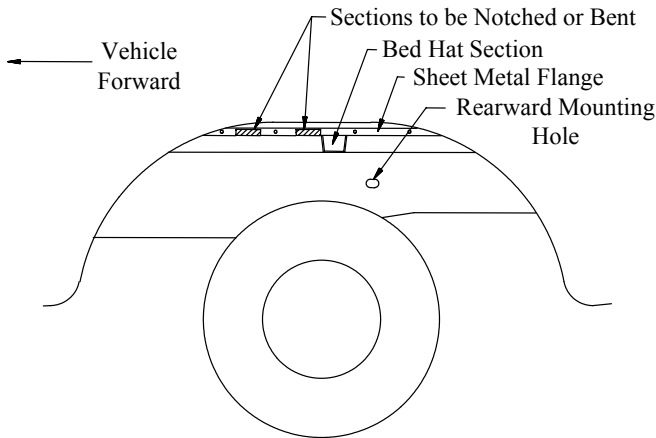
3. From the driver's side wheel well, notch or bend the sheet metal flange as shown in Figure 3. (**Optional:** The vehicle bed can be lifted to insert the hitch cross members by loosening the bolts that attach the bed to the frame).
4. Slide the hitch cross members half way through the notches or bends in the sheet metal flange and place 5/8 carriage bolts from the 9461/9463 fastener kit into the long slots from underneath the vehicle. Slide the hitch cross members above both vehicle frame rails and align hitch cross members as shown in Figure 4.
5. Place 1/4 X 1.00 X 3.00 blocks and 1/2-13 X 2.75 hex bolts through slots in the driver's side and passenger's side of vehicle frame pointing outwards.
6. Install the hitch frame brackets by aligning the rearward holes in the brackets with the fasteners installed in installation step 5. Loosely install the 5/8-11 X 1.50 hex bolts, lock washers, and flat washers through the slot in the hitch frame brackets and into the threaded blocks on the ends of the hitch cross members (see Figure 5).
7. Install the frame bracket clamp by placing the clamp to the inside of the frame rail, insert the 1/2-13 X 4.50 GR5 carriage bolts through the square holes in the clamp and through the frame bracket with the threaded end pointing outwards. Install the lock washers and hex nuts.
8. When installing the 9461/9463 Hide-A-Goose hitch, a 4" hole must be drilled in the bed of the truck. Mark and drill a 1/4" hole **44-3/4 inches (short box) / 49-1/2 inches (long box)** from the rear of the bed and centered between the wheel wells. Refer to the 9461/9463 Hide-A-Goose hitch instruction sheet. Drill the 4 inch hole in the bed of the truck with a 4" hole saw using the 1/4" hole as a pilot.
9. Place the trim ring from the 9461/9463 Hide-A-Goose kit into the 4" opening.
10. Loosely install the 9461/9463 Hide-A-Goose hitch. Refer to the 9461/9463 instruction sheet.
11. After fully installing the 9461/9463 Hide-A-Goose hitch and 4431 mounting kit, carefully align the hitch ball sleeve with the 4" opening and the trim ring in the truck bed. Torque all 5/8-11 GR5 fasteners on the brackets to 150 ft.-lb. (203 N-m) and 1/2-13 GR5 fasteners to 75 ft.-lb. (102 N-m). Use the following sequence: a) torque frame brackets to the frame of the vehicle, b) torque cross members to the frame brackets c) torque Hide-A-Goose hitch to cross members.
12. If sheet metal flange is notched or bent in installation step 4, use paint to prevent corrosion on the sheet metal flange. If vehicle bed was lifted to insert cross member, tighten bolts that attach the bed to the frame.

# Installation Instructions

Part Numbers:

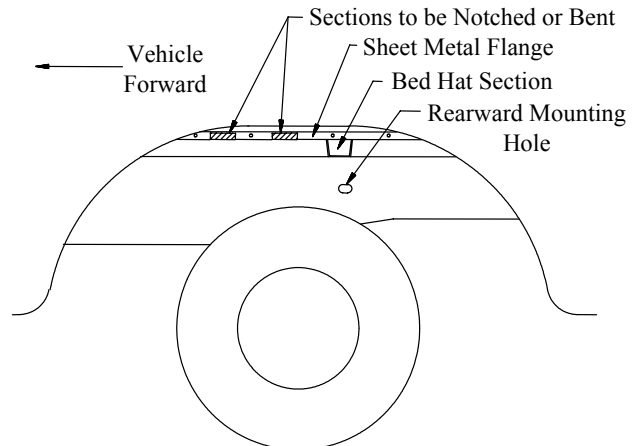
Chevrolet/GMC 1500 Short & Long Bed  
2500 Light Duty Short Bed

**4431**



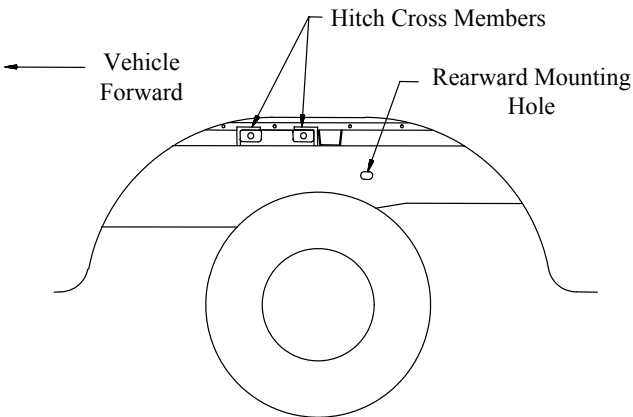
**Figure 3**

Short Bed – Hide-A-Goose



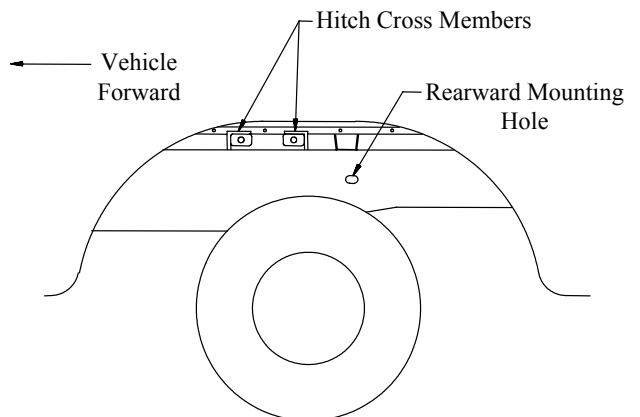
**Figure 3**

Long Bed – Hide-A-Goose



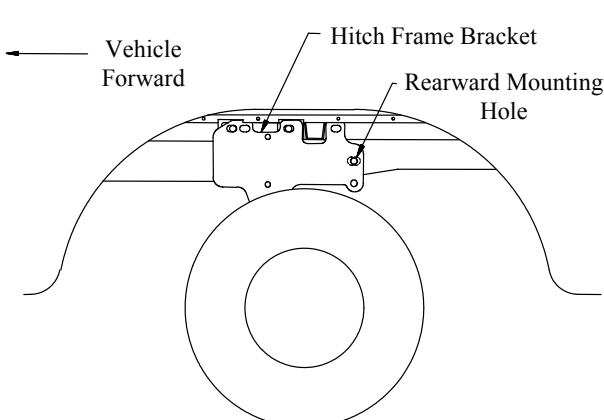
**Figure 4**

Short Bed – Hide-A-Goose



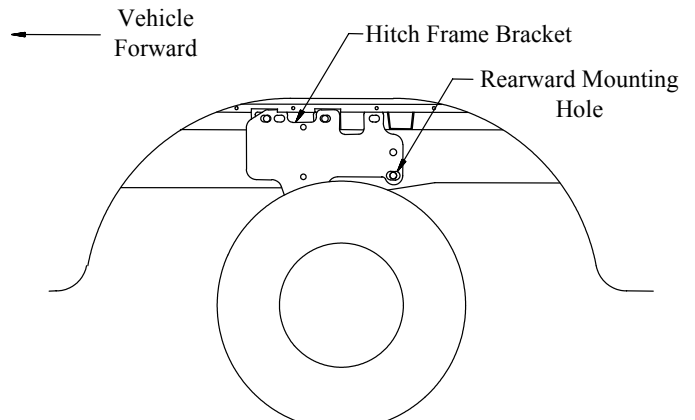
**Figure 4**

Long Bed – Hide-A-Goose



**Figure 5**

Short Bed – Hide-A-Goose



**Figure 5**

Long Bed – Hide-A-Goose



# Installation Instructions

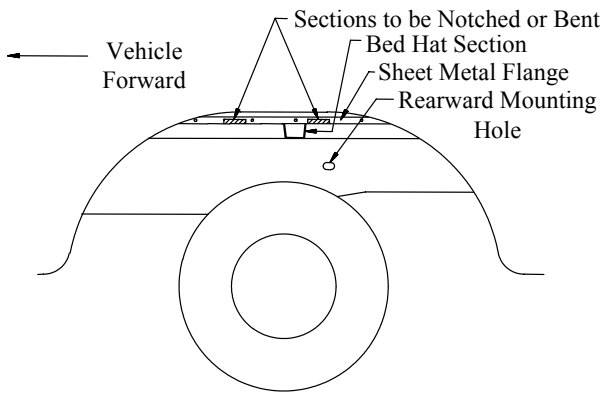
Part Numbers:

Chevrolet/GMC 1500 Short & Long Bed  
2500 Light Duty Short Bed

**4431**

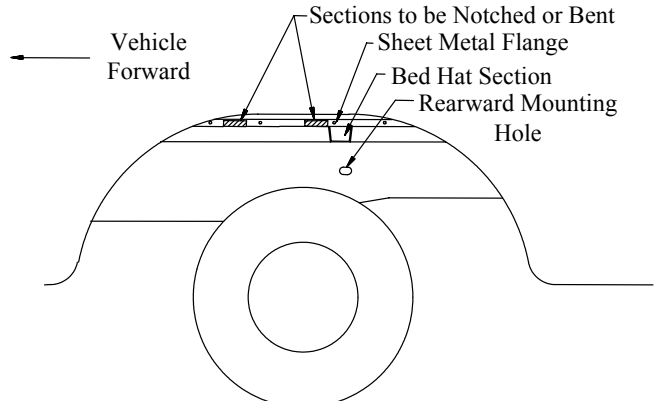
16. Install the 5/8 X 2.50 GR5 carriage bolts through the platform, shims and cross members. Secure with lock washers and nuts. Torque nuts to 150 ft.-lb. (203 N-m).

17. Install the (2) U-bolts through the platform and from under the vehicle install the large flat washer over the U-bolt followed by a spring, another large flat washer and secure with a thin 5/8" jam nut. Repeat for the other legs of the U-bolts. The 5/8" jam nuts are tightened until (3) threads are visible past the bottom of the jam nut.



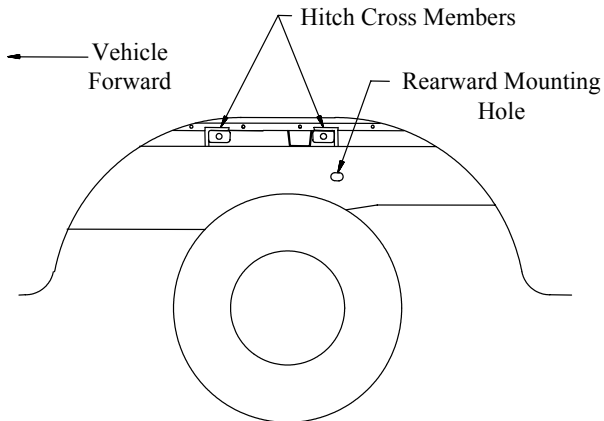
**Figure 6**  
**Short Bed**

Remove-A-Ball/Fold Down Gooseneck



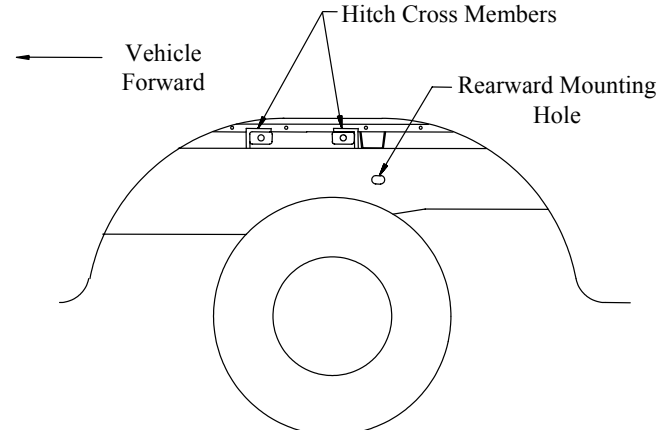
**Figure 6**  
**Long Bed**

Remove-A-Ball/Fold Down Gooseneck



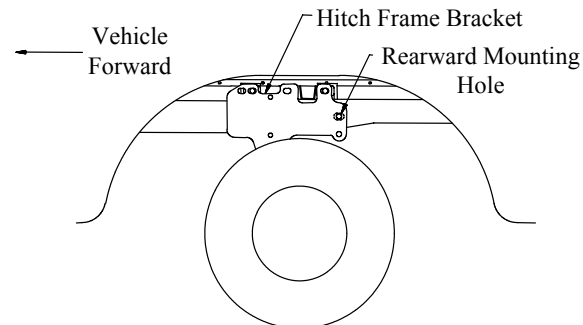
**Figure 7**  
**Short Bed**

Remove-A-Ball/Fold Down Gooseneck

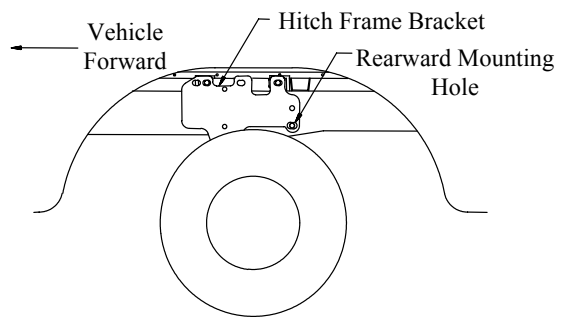


**Figure 7**  
**Long Bed**

Remove-A-Ball/Fold Down Gooseneck



**Figure 8 - Short Bed**



**Figure 8 - Long Bed**