

INSTALLATION INSTRUCTIONS

VEHICLE
BUICK PARK AVENUE

EQUIPMENT REQUIRED:

WIRING ACCESS LOCATION: PC3, PC4

DRILL BITS: 1/2

HITCH REQUIRES 1/2" PIN AND CLIP

WRENCHES: (TIGHTEN ALL FASTENERS WITH TORQUE WRENCH) 13mm, 15mm, 17mm, 7/8

3500 LB MAX GROSS TRAILER WT
300 LB MAX TONGUE WEIGHT
DO NOT EXCEED TOWING VEHICLE RATINGS

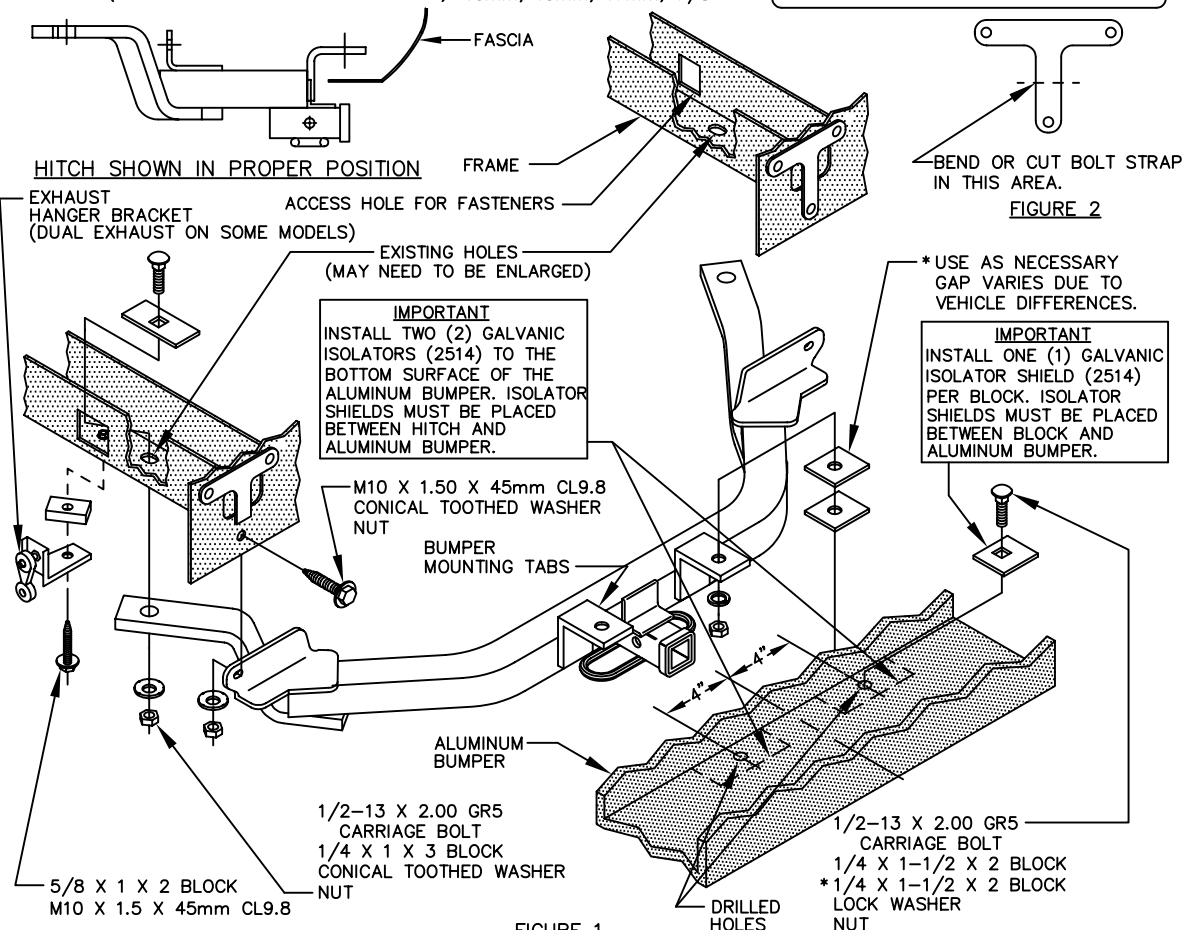
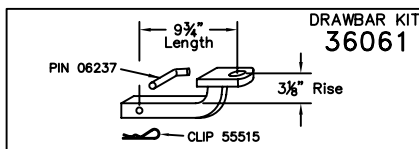

FIGURE 1

1. SUPPORT THE EXHAUST AND REMOVE THE BOLT HOLDING THE EXHAUST HANGER BRACKET TO THE BOTTOM OF THE FRAME.
NOTE: SOME MODELS HAVE DUAL EXHAUST.
2. PLACE TWO (2) GALVANIC ISOLATORS ON BOTTOM SURFACE OF THE BUMPER AT EACH ATTACHING LOCATION. THE ISOLATORS ARE TO BE LOCATED 4" FROM THE VEHICLE CENTERLINE. THE BUMPER MUST BE COMPLETELY COVERED WITH THE GALVANIC ISOLATOR WHERE IT MAKES CONTACT WITH THE HITCH ASSEMBLY.
3. LOOSEN THE TOP TWO NUTS AND REMOVE THE BOTTOM NUT FROM THE BOLT STRAP WHICH ATTACHES THE BUMPER TO THE VEHICLE FRAME. BEND THE BOTTOM TAB OUT OF THE WAY OR CUT TAB IF NEEDED. SEE FIGURE 2.
4. RAISE RECEIVER INTO POSITION, ALIGNING HOLES IN RECEIVER WITH EXISTING E/A ATTACHMENT POINTS ON VEHICLE.
NOTE: E/A ATTACHMENT HOLES MAY NEED TO BE ENLARGED.
5. LOOSELY INSTALL M10 X 1.50 X 45mm BOLTS, 3/8 CONICAL TOOTHED WASHERS & NUTS AS SHOWN ABOVE.
6. USING HITCH AS A TEMPLATE, DRILL 1/2" HOLES IN BUMPER.
7. PLACE GALVANIC ISOLATORS ON EACH 1/4 X 1-1/2 X 2 BLOCK.
8. FISHWIRE THE 1/2-13 X 2.00 CARRIAGE BOLTS & BLOCKS THROUGH THE END OF THE BUMPER & THROUGH THE HOLES DRILLED IN STEP 6.
NOTE: GALVANIC ISOLATORS MUST BE BETWEEN THE BLOCK AND BUMPER.
9. FISHWIRE FORWARD FASTENERS AS SHOWN. A REINFORCEMENT INSIDE THE FRAME MAY REQUIRE THE EXISTING HOLE TO BE ENLARGED.
10. ADD A 5/8 X 1 X 2 BLOCK AS A SPACER BETWEEN THE FRAME AND THE EXHAUST HANGER BRACKET. IF EQUIPPED WITH DUAL EXHAUST REPEAT ON OPPOSITE SIDE. REINSTALL EXHAUST HANGER BRACKET REMOVED IN STEP 1 WITH M10 X 1.50 X 45mm BOLT PROVIDED.

TIGHTEN M10 CL9.8 FASTENERS TO 42 LB.-FT.
TIGHTEN 1/2 GR5 FASTENERS TO 75 LB.-FT.



USE ONLY THE DRAWBAR SHOWN FOR CORRECT BUMPER CLEARANCE AND HEIGHT.
DRAWBAR MUST BE USED IN THE RISE POSITION ONLY.

THIS PRODUCT COMPLIES WITH SAFETY SPECIFICATIONS AND REQUIREMENTS FOR CONNECTING DEVICES AND TOWING SYSTEMS OF THE STATE OF NEW YORK, V.E.S.C. REGULATION V-5 AND SAE J684.

APPROX WEIGHT (LB.)	FASTENER KIT
32.5	01131-022

NOTE: Check hitch frequently, making sure all fasteners and ball are properly tightened. If hitch is removed, plug all holes in trunk pan or other body panels to prevent entry of water and exhaust fumes. A hitch or ball which has been damaged should be removed and replaced. Observe safety precautions when working beneath a vehicle and wear eye protection. Follow car maker's specs for maximum trailer weight and tongue weight. Do not cut access or attachment holes with a torch.

TOWING PRODUCTS
Plymouth, Michigan