

16K

Signature Series

INSTALLATION INSTRUCTIONS MOUNTING KIT FORD F250/F350/F450 LD/HD/SD 6' & 8' Beds

18K

Signature Series

DO NOT EXCEED VEHICLE MANUFACTURER'S RATING FOR 5th WHEEL TOWING OR MAXIMUM GROSS TRAILER WEIGHT OF 18,000lb. / 8160kg.

DEALER/INSTALLER:

- (1) Provide this Manual to end user.
- (2) Physically demonstrate procedures in this Manual to end user.
- (3) Have end user demonstrate that he/she understands procedures.

END USER:

- (1) Read and follow this Manual every time you use Hitch.
- (2) Save this Manual for future reference.
- (3) Pass on copies of Manual to any other user or owner of Hitch.

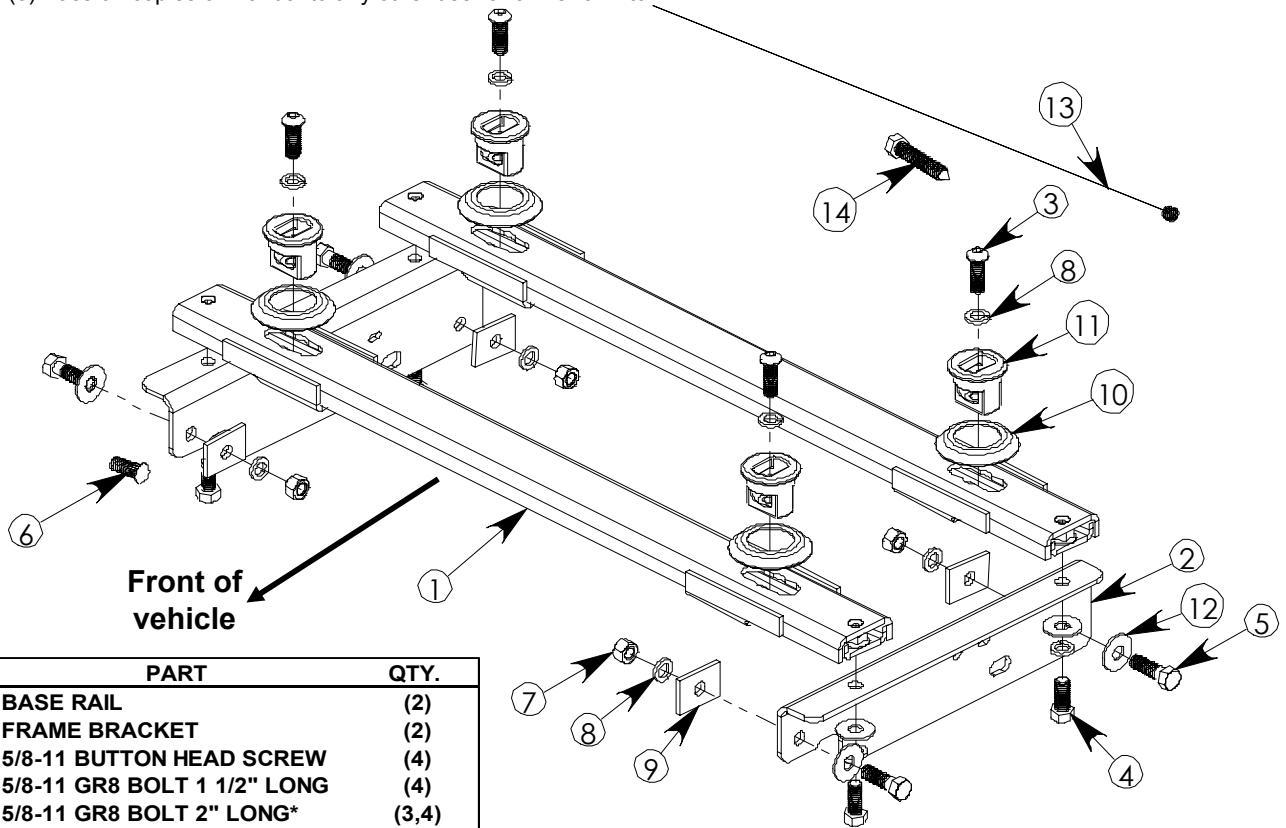

PART	QTY.
1. BASE RAIL	(2)
2. FRAME BRACKET	(2)
3. 5/8-11 BUTTON HEAD SCREW	(4)
4. 5/8-11 GR8 BOLT 1 1/2" LONG	(4)
5. 5/8-11 GR8 BOLT 2" LONG*	(3,4)
6. 5/8-11 GR8 KNURL BOLT*	(1)
7. 5/8-11 GR8 NUT	(4)
8. 5/8 LOCK WASHER	(12)
9. SPACER*	(3,4)
10. TRIM RING	(4)
11. PUCK	(4)
12. 5/8 FLAT WASHER	(8)
13. 5/8-11 PULL WIRE*	(2)
14. 5/8-11 X 3 1/2" WITH POINT	(1)

* FOR 2005 SUPER DUTY KNURL BOLT AND PULL WIRE REPLACE ONE EACH OF BOLT AND SPACER

Figure 1

For Customer Support
Call 1-800-632-3290

⚠ WARNING:

Failure to follow all of these instructions may result in death or serious injury!

INDEX

- | | |
|--|--------|
| 1. GUIDELINES FOR MATCHING TOW VEHICLE AND TRAILER | P. 2-4 |
| 2. ASSEMBLY INSTRUCTIONS | P. 5-9 |
| 3. CEQUENT TOWING PRODUCTS SEVEN YEAR LIMITED WARRANTY | P. 10 |

GUIDELINES FOR MATCHING HITCH TRUCK AND TRAILER

⚠ WARNING:

Failure to check and follow tow ratings could result in tow vehicle damage or truck and trailer separation while towing.

- Trailer and its contents together must not exceed truck, hitch and/or trailer tow ratings.
- Towing vehicle must have a manufacturer's rated towing capacity equal to or greater than the gross trailer weight (dry weight of the trailer plus payload of the trailer). (Figure 2)
- Gross weight of trailer must not exceed fifth wheel hitch rating.
- King pin weight must not exceed fifth wheel rating (Figure 3). If in doubt have king pin weight measured by a qualified technician.

Figure 2

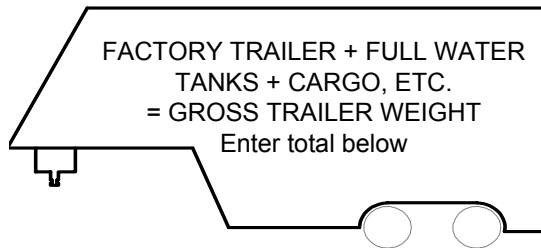

1. Maximum Gross Trailer Weight of : **18,000 lb / 8160kg.**
Vehicle tow rating: _____.
Total calculated Gross Trailer Weight (Figure 2): _____.
***Trailer weight should be the lowest of these recorded ratings for safe towing conditions.**
2. Cequent Towing Products hitches are designed for use with recreational fifth wheel trailers only. Hitch applications other than recreational fifth wheel trailers must be approved in writing by Cequent Towing Products' Engineering Department.
3. Use only a SAE 2-inch kingpin with your *Signature Series* Fifth Wheel Hitch.
4. Approximately 15%-25% of trailer weight should be on hitch (Pin Weight)(Figure 3).

Figure 3

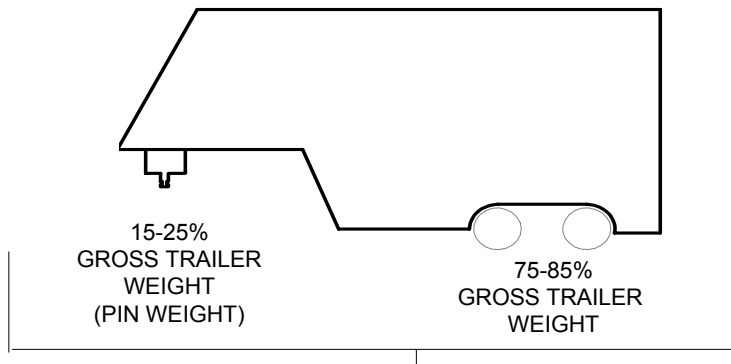

5. Trucks come in many different configurations. **Cequent Towing Products'** hitches are designed for use in light trucks such as the Ford F-Series, the Chevy Silverado and the Dodge Ram. **Cequent Towing Products** recommends the use of long bed (8ft) light trucks for the best combination in truck - trailer turning clearance.

Rule of thumb: The distance from the back of the truck cab to the center of the rear truck axle ("X" in **Figure 4**), should be approximately 4 inches greater than one-half the trailer width ("Y" in **Figure 4**)

Figure 4

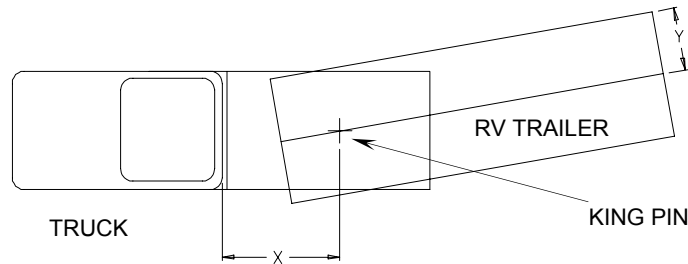

6. If a short bed pickup (less than 8 ft. but longer than 6 ft.) is to be used for towing, **Cequent Towing Products** recommends the trailer be equipped with an extended pin box to help gain additional truck - trailer turning clearance (See trailer manufacturer for options) (**Figure 5**). It also may be helpful to add a *Signature Series* Slider (**Part # 30070**) for increased turning clearance for low speed, non-highway maneuvering.

Figure 5

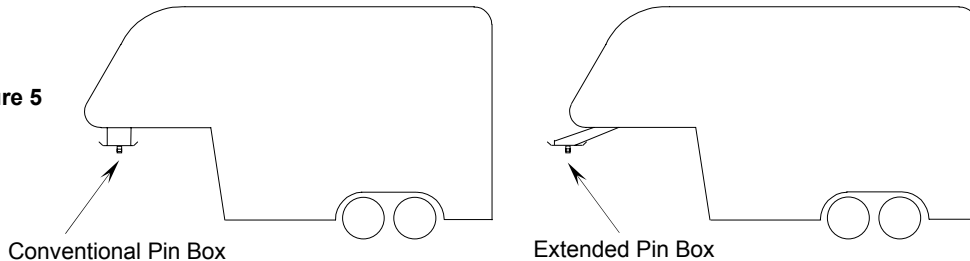

⚠ WARNING:

Do Not install this fifth wheel hitch on or attempt to tow with a short bed pickup truck that has a bed shorter than 6 ft.!

7. The height of the hitch and the pin box should be adjusted so the trailer is approximately level as it is towed. Allow approximately 6 inches clearance between the top of the pickup walls and the underside of the front of the trailer for pitch and roll of the trailer. (**Figure 6**). Allow more clearance between pickup walls and trailer for off road use.

Figure 6

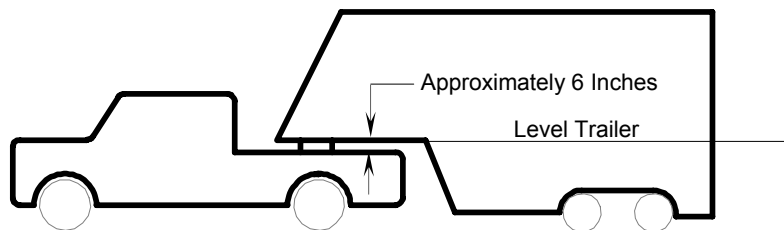

CAUTION:

The measurements above are guidelines. If your measurements are close to these numbers re-check clearances. If vehicle and/or trailer has any added bed vicinity accessories (i.e. fairings, air dams, ground effects, bed rails, etc.). Additional dimensioning and clearance checks have to be made.

8. Hitch height determination:

With trailer leveled and on level ground measure from the ground to the king pin box ("A" in **Figure 7**). Secondly measure from the height of the inside of the truck bed ("B" in **Figure 7**). Determine the amount of clearance over the side rails ("C" and "D" in **Figure 7**), as mentioned in **Note 7**.

$$\text{Hitch Height} = A - B + 2''$$

The 2" value is an estimate of suspension compression due to king pin weight of the trailer. This compression could range between 1"-5" depending on the truck being used and the trailer being towed.

$$D - C + 2'' > 6'' \text{ as in Note 7.}$$

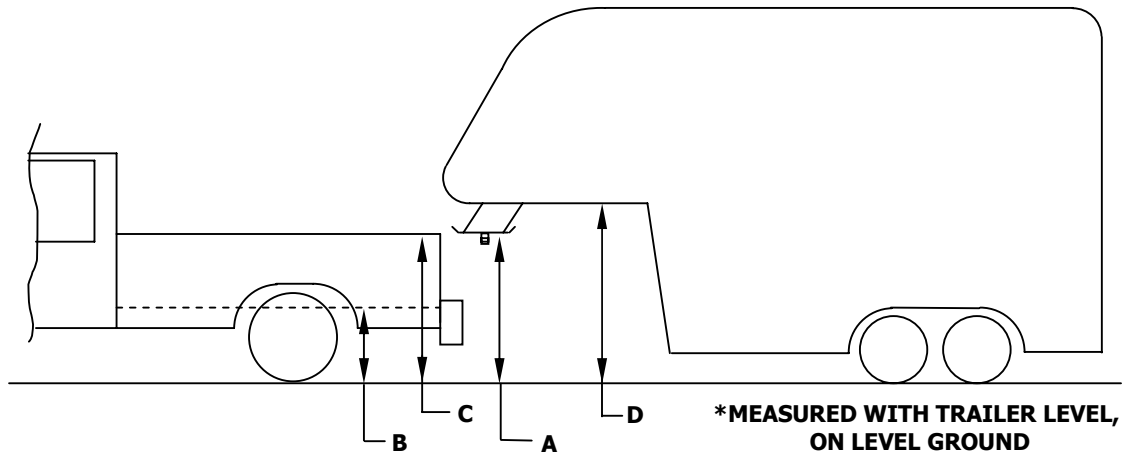

Figure 7

9. If a lube plate is to be used with a Signature Series 5th Wheel it must be at least 12" in diameter. **Cequent Towing Products** offers this optional lube plate as part # 83001 / 40001.

⚠ WARNING:

- Connection for trailer wiring must be located at the side of the truck bed between the driver's seat and the rear wheel to prevent operators from working between the truck and trailer.
- Avoid putting any part of your body under the trailer or between the truck and trailer. Unexpected or accidental movement of the truck or the trailer can cause serious injury or death
- If you must place any part of your body under the trailer or between the truck and trailer you **MUST** perform **ALL** of the following steps:
 - Check that the truck transmission is in park
 - Check that the emergency brake is on
 - Block in front of and behind all trailer tires
 - Check that the trailer landing gear are resting on firm ground

GENERAL INSTRUCTIONS FOR FIFTH WHEEL INSTALLATION

TOOLS

3/16" Drill	15/16" Socket & Open End Wrench
21/32" Drill	200 lb-ft Torque Wrench
3/8" Hex socket	2-1/2" Hole Saw
Rubber Mallet	5/8-11 x 3 1/2" w/point
Vice grips or pliers	
Optional for 2005 Super Duty:	5/8-11 Pull Wire

CAUTION!

Read pages 2-4 of these instructions before starting installation. Failure to do so could result in significant vehicle damage!

1. The following instructions should be used to mount the 5th wheel. Care and attention to detail will ensure a quick quality installation. Check parts against parts list to become familiar with parts in kit. (Figure 1)
2. Raise rear of truck high enough to allow jack stands to be placed under rear spring hanger bracket of truck. This will provide maximum room to install the 5th wheel brackets.



WARNING:

If the truck is raised, be sure that the truck is properly blocked and restrained to prevent the truck from falling. Failure to do so may result in the truck suddenly falling, causing death or serious injury.

3. **Remove plastic bed liner if applicable.** Plastic drop-in bed liners will be cut later. Spray-in bed liners and bed mats less than 1/4" thick will work with normal installation instructions. **Note:** Consult installer for recommended curing time on spray-in liner before cutting holes through bed.

CAUTION:

Check for obstructions before drilling. Failure to do so could result in damaged fuel or brake lines, structural members, etc. **CEQUENT TOWING PRODUCTS** does its best to communicate tow vehicle manufacturer changes; however, it is ultimately the responsibility of the installer to prevent damage due to installation.

4. Use only **CEQUENT TOWING PRODUCTS** supplied bolts, nuts, and washers to install this kit. All bolts and nuts are grade 8 unless specified otherwise.
5. These instructions are intended for a specific group of trucks. If these instructions do not apply to your vehicle, contact Technical Service to get proper instructions. Each frame bracket must be bolted to the vehicle frame with two bolts.
6. On older models a metal heat shield runs underneath truck bed. Remove and discard heat shield from beneath truck bed if applicable. Heat shield adhered to bottom of bed on newer models does not need to be removed.

CAUTION:

These instructions are guidelines only. Actual installation is the responsibility of the installer and the owner. Always measure truck and trailer before installing hitch to be sure that there is clearance at the cab and at the bumper to allow for turns.

7. Locate the area where the base rails will be inserted above the wheel on the drivers side. There are two hat channels supporting the truck bed over the wheel. The base rails will be inserted at the location behind the forward hat channel. The edge of the truck bed is flanged down. To create clearance for inserting the rails there are two options. Either loosen truck bed bolts to lift truck bed, or the flanged area must be bent out using pliers or vice grips. (Figure 8) To prevent scratching the paint on the flange cover the flange with a soft cloth before gripping with pliers or vice grips.

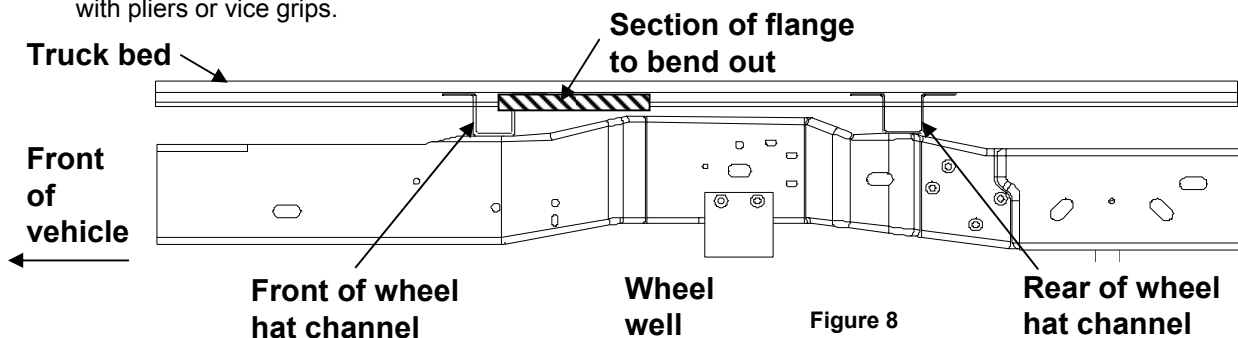

8. Insert rails as shown in the following steps (Figures 9 through 11). Rails should be inserted flat side up.

Step 1 : Insert the first rail from the drivers side wheel well above the frame. Rest the rail on both chassis frame rails (Figure 9).

Forward

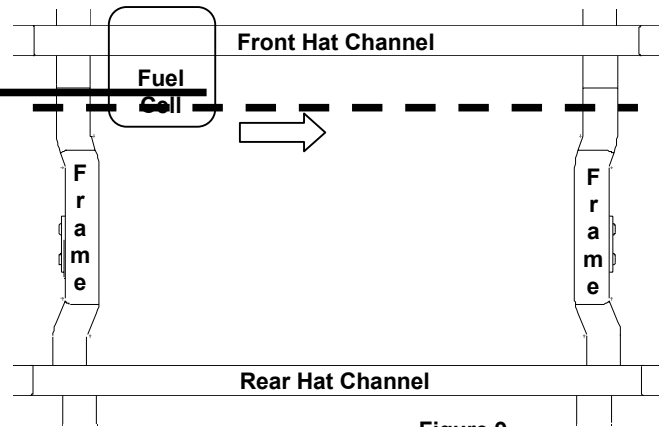
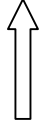
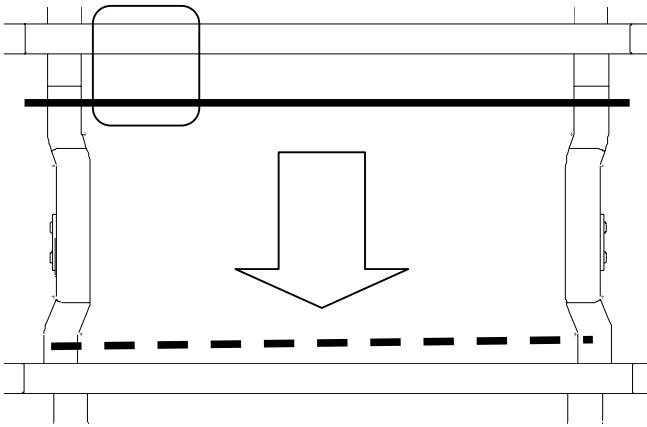

Figure 9

Step 2 : Slide the rail rearward, parallel with axle, resting on both frame rails, and as close as possible to the rear hat channel (Figure 10).

Figure 10



Step 3 : Insert the second rail from the drivers side wheel well above the frame. Rest the rail on both chassis frame rails (Figure 11).

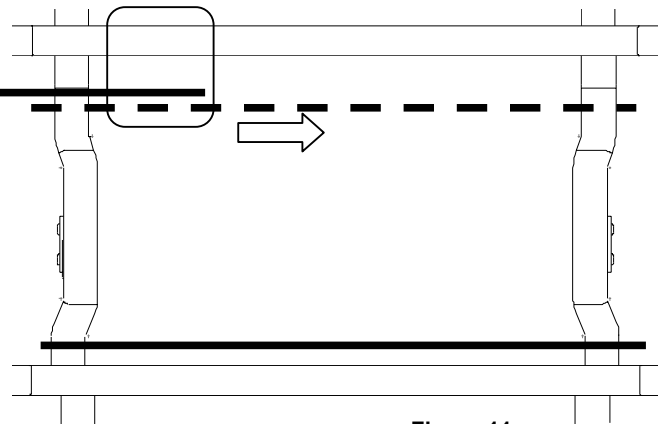
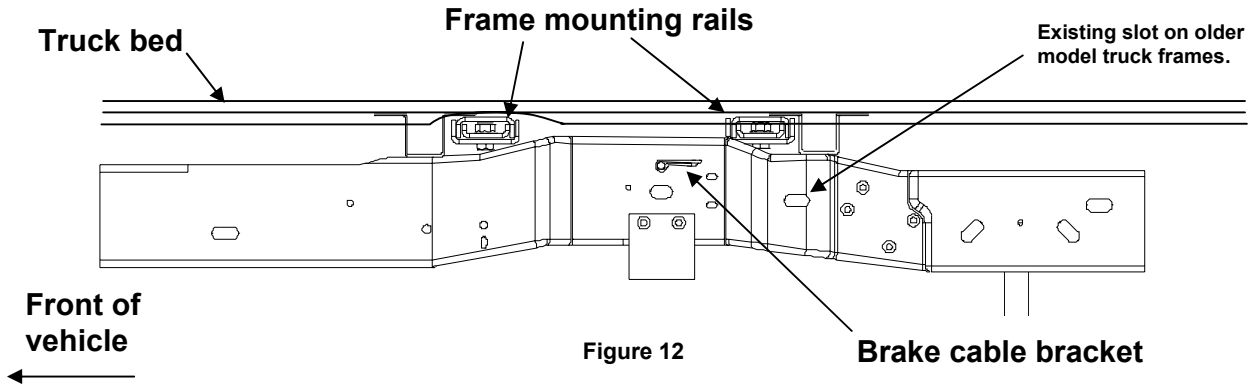

Figure 11

Step 4 : One rail should be rearward and the other rail forward. The rails should be centered with both ends of each rail resting evenly on the frame. After rails are inserted and in place the flanged area of the bed liner can be straightened with vice grips or pliers, be sure to use a soft cloth before gripping flange to prevent scratching. If flanged area is scratched immediately follow manufacturer's recommended method of touching up scratched area to prevent rust or other corrosion.

9. If there is a brake cable bracket located above the rear axle on the driver's side of the frame, then disassemble and remove the brake cable bracket (**Figure 12**). Do not discard the brake cable bracket it will be re-attached later.



10. If brake cable bracket was removed in previous step, then re-locate brake cable bracket to rail bracket through hole given in the frame rail bracket using the original brake cable bracket hardware, tighten brake cable hardware with a wrench (**Figure 13**). Do not attempt to re-attach brake cable bracket through chassis rail.

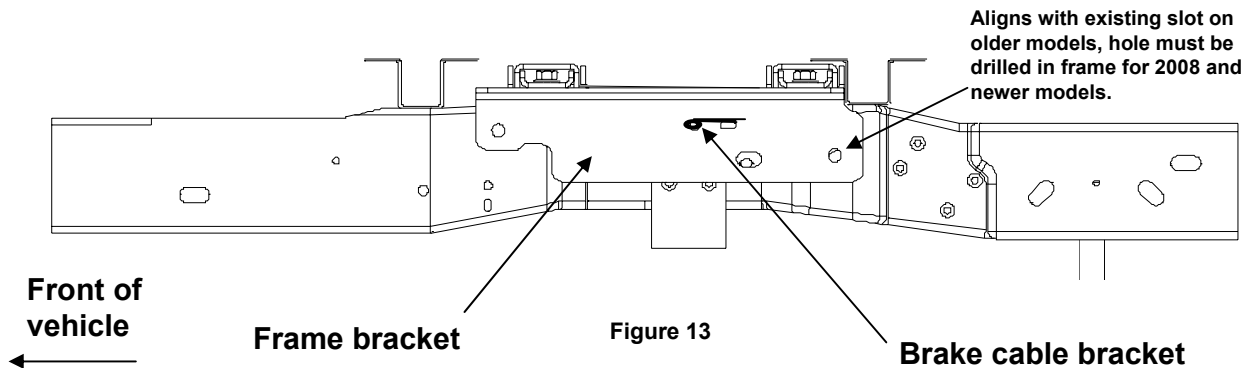

⚠ WARNING:
DO NOT lubricate threads. It may cause bolt failure.

11. Loosely attach frame brackets to mounting kit rails using 5/8" X 1 1/2" long bolts, flat washer, and lock washers (**Figure 14**). Tighten all mounting kit bolts to hand tight.

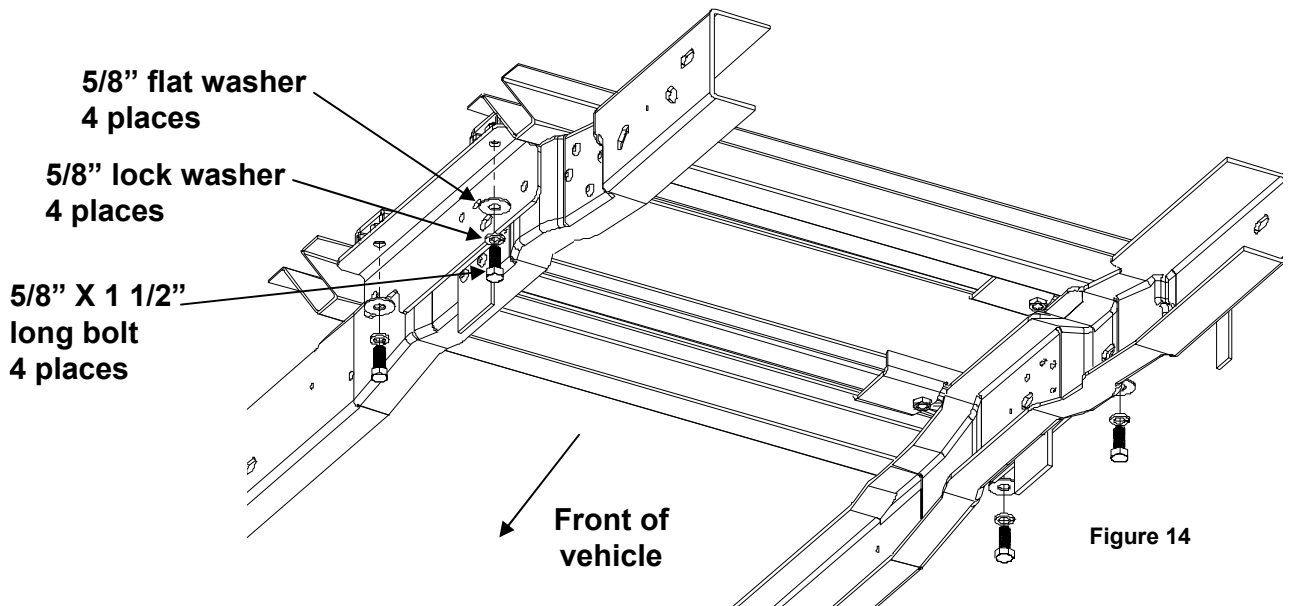

CAUTION:

Check for obstructions before drilling. Failure to do so could result in damaged fuel or brake lines, structural members, etc. **CEQUENT TOWING PRODUCTS** does its best to communicate tow vehicle manufacturer changes; however, it is ultimately the responsibility of the installer to prevent damage due to installation.

12. Align hole in bracket with hole in chassis for 2007 and earlier models. After checking to ensure that rails are square with each other, at forward mount hole location, drill pilot hole in frame using frame bracket as a template. For 2008 and newer models, position complete assembly near or against truck bed hat channel towards rear of vehicle and drill a pilot hole in frame, both sides. Enlarge pilot holes to 21/32" diameter holes (**Figure 15**). **Optional:** Spray undercoating around drilled holes to prevent rusting.

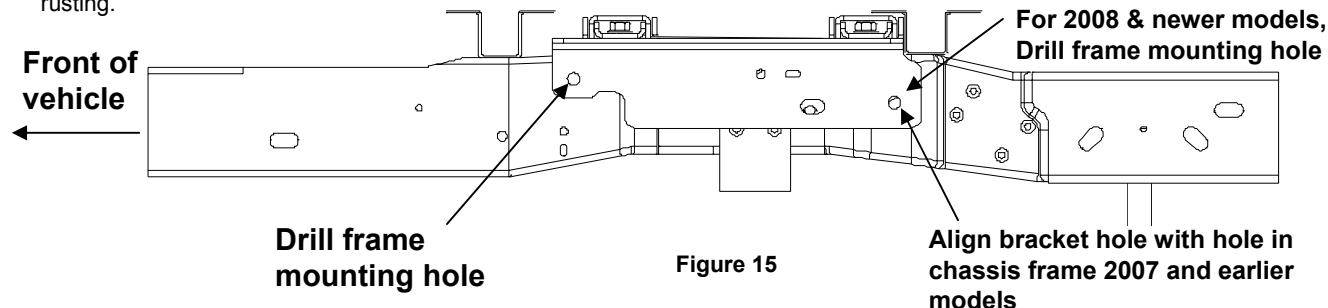

- 13A. Loosely attach frame bracket to chassis frame using 5/8" X 2" bolts, washer, spacers, lock washers, and nut. Tighten to hand tight (**Figure 16**). With 2005 and newer super duty models, suspension components may block access to the front drilled hole on the passenger side of the vehicle. Use supplemental instruction 13B for use of the knurl bolt in the forward passenger side hole.

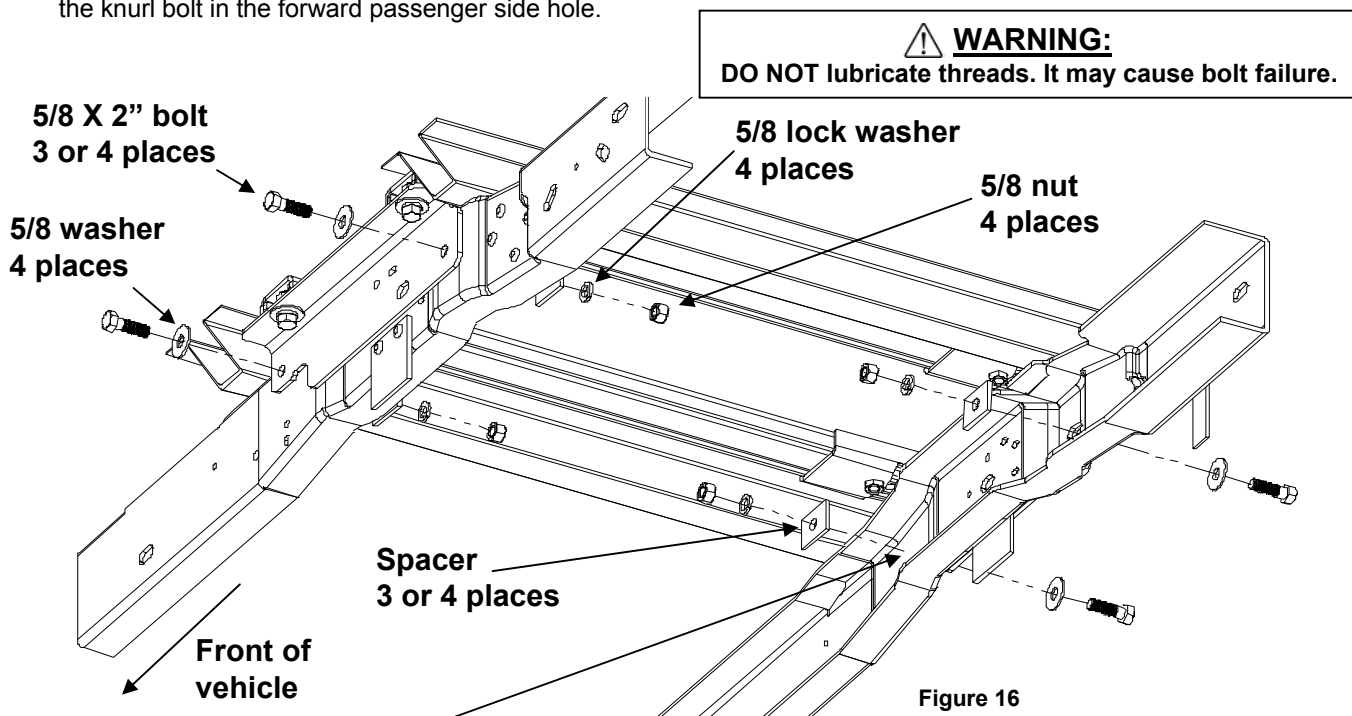

Optional: 5/8" knurl bolt and pull wire inserted here and pulled through chassis rail and mounting hole in bracket

- 13B. With 2005 and newer super duty models where suspension components block access to the front drilled hole on the passenger side of the vehicle thread 5/8" x 1 1/2" knurl bolt onto pull wire (**Figure 17**). From the inside of the chassis rails insert straight end of pull wire into drilled hole. Pull wire out through drilled hole and mounting hole in bracket (**Figure 16**), unthread pull wire from knurl bolt. Thread washer, lock washer, and nut onto knurl bolt from the outside of chassis rails and tighten until hand tight.

Note: Standard bolt and spacer will not be used in this case.

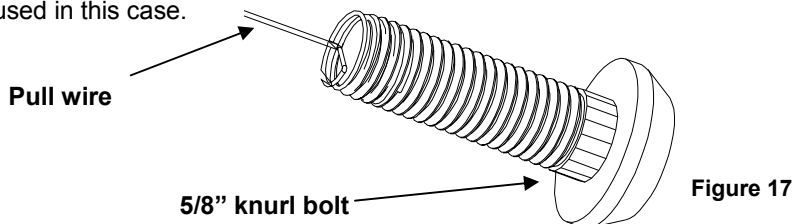

**Thread pointed bolt through welded nuts
4 places**

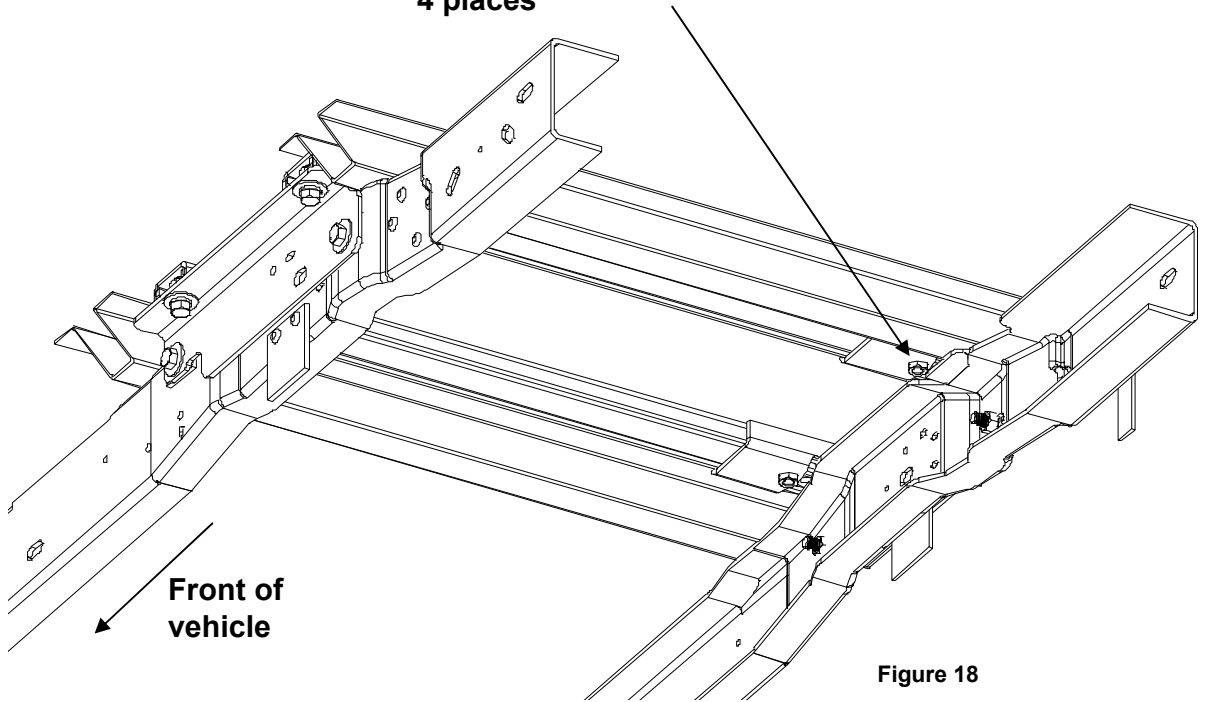

Figure 18

14. Using pointed bolt (**Figure 19**), screw pointed bolt in to the nut that is welded to the rail assembly until a prick mark is clearly visible on the truck bed (**Figure 18**). If access to a welded nut is obstructed by chassis components, a fourth prick mark should be made on the bed based upon measuring from the other prick marks (**Figure 20**). If a plastic bed liner is used cut 19" X 4" slots in the liner measured from prick marks in truck bed. If the *Signature Series* slider fifth wheel assembly is used, then see fifth wheel slider assembly instructions for slot cut dimensions.

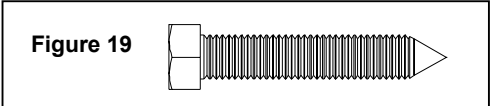

Figure 19

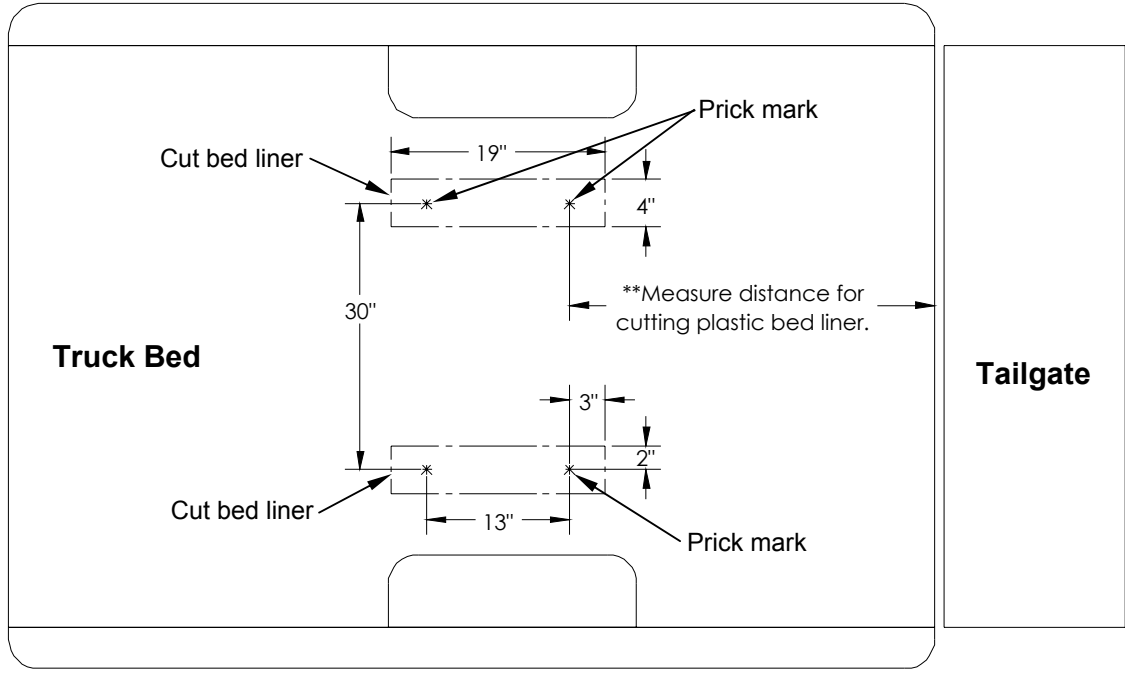

Figure 20

- Remove 5/8" x 1 1/2" bolts attaching frame bracket to mounting rails. Remove front rail as per instructions in step 7. Move rear rail rearward or forward to prevent interference with hole drilling or punching of truck bed.

CAUTION:

Check for obstructions before drilling. Failure to do so could result in damaged fuel or brake lines, structural members, etc. **CEQUENT TOWING PRODUCTS** does its best to communicate tow vehicle manufacturer changes; however, it is ultimately the responsibility of the installer to prevent damage due to installation.

- Drill pilot holes in truck bed at prick mark locations. With hole saw saw 2 1/2" hole centered at pilot holes.

Note: Consult installer for recommended curing time on spray-in liner before cutting holes through bed.

Optional: Spray under coating around 2 1/2" holes to prevent rusting.
- Loosely reattach rails to frame bracket.
- From truck bed attach pucks and trim rings to rails as shown in **Figure 21** using 5/8" button head screw and lock washer. Tighten to 110ft.lbs. torque.

WARNING:
DO NOT lubricate threads. It may cause bolt failure.

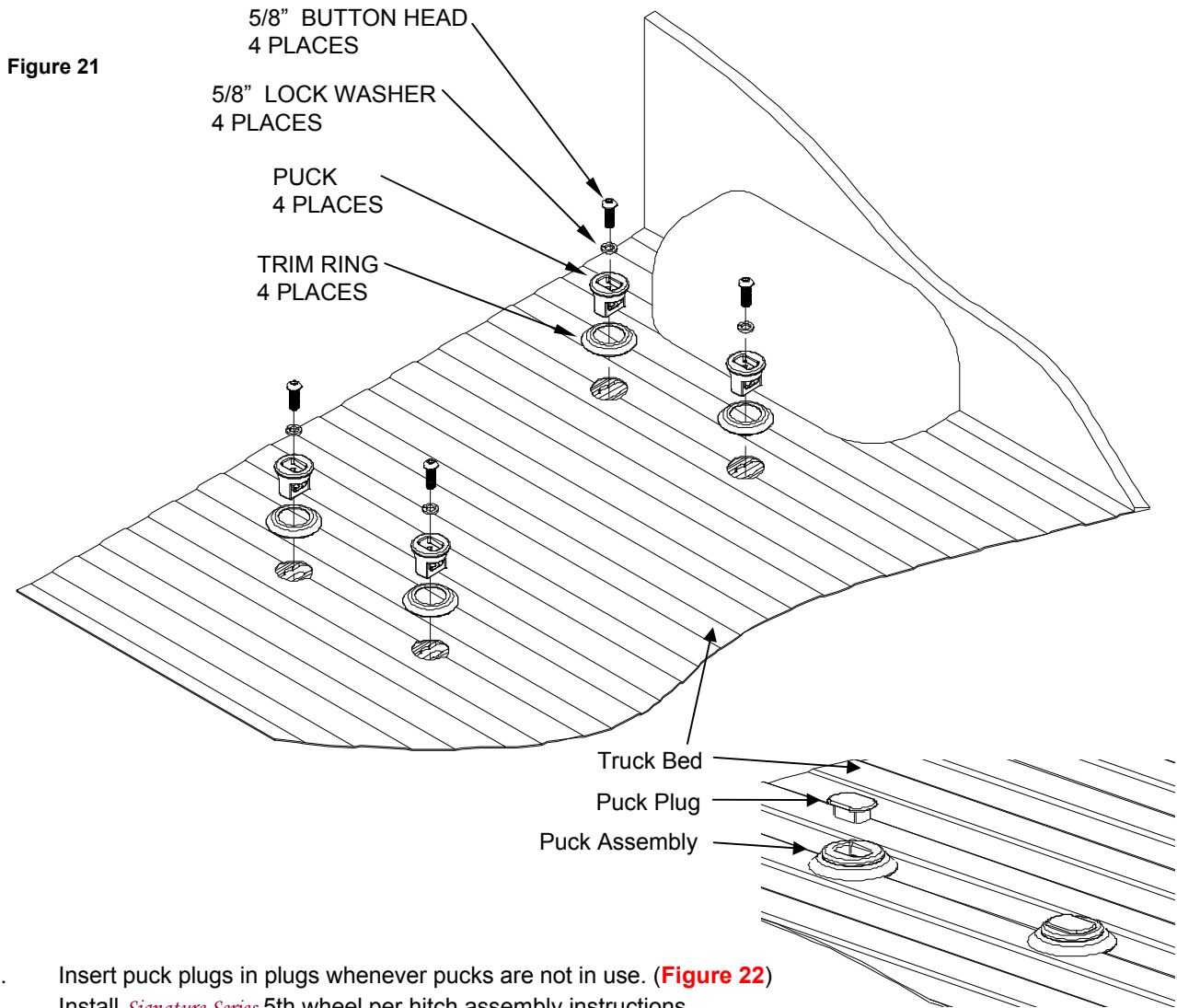

Figure 22

- Insert puck plugs in plugs whenever pucks are not in use. (**Figure 22**)
- Install *Signature Series* 5th wheel per hitch assembly instructions.
- Torque hitch assembly bolts per hitch instructions.
- Torque all 5/8" rail kit hex bolts to 170ft.lbs
- Replace any brake lines and spare tire that may have been removed/relocated.

NOTES

SEVEN YEAR LIMITED WARRANTY

Hitches - Custom Receivers

Cequent Towing Products warrants the *Signature Series* 5th Wheel Hitch Mounting Kits from date of purchase against defects in material and workmanship under normal use and service, ordinary wear and tear excepted, for 7 years of ownership to the original consumer purchaser when a Cequent Towing Products *Signature Series* 5th Wheel Hitch is used.

Cequent Towing Products will replace FREE OF CHARGE any part which proves defective in material or workmanship when presented to any Cequent Towing Products dealer, Cequent Towing Products Warehouse or returned to factory. TRANSPORTATION CHARGES PREPAID, at the address below. THIS WARRANTY IS LIMITED TO DEFECTIVE PARTS REPLACEMENT ONLY. LABOR CHARGES AND/OR DAMAGE INCURRED IN INSTALLATION OR REPLACEMENT AS WELL AS INCIDENTAL AND CONSEQUENTIAL DAMAGES CONNECTED THEREWITH ARE EXCLUDED.

Some states do not allow the exclusion or limitation of incidental or consequential damages, so the above limitation or exclusion may not apply to you.

Any damage to the *Signature Series* 5th Wheel Hitch as a result of misuse, abuse, neglect, accident, improper installation, or any use violative of instructions furnished by us, WILL VOID THE WARRANTY.

This warranty gives you specific legal rights, and you may also have other rights which vary from state to state. In the event of a problem with warranty service or performance, you may be able to go to a small claims court, or a federal district court.

Cequent Towing Products, Inc.
47774 Anchor Court
Plymouth, MI 48170