

INSTALLATION INSTRUCTION

VEHICLE
CHEVROLET CAVALIER
PONTIAC SUNFIRE

HITCH NO.
 24733
 77049

EQUIPMENT REQUIRED:

WIRING ACCESS LOCATION: PC3, PC4

DRILL BITS: 7/16

HITCH REQUIRES 1/2" PIN AND CLIP

WRENCHES: (TIGHTEN ALL FASTENERS WITH TORQUE WRENCH) 9/16, 11/16, 13mm

2000 LB MAX GROSS TRAILER WT
 200 LB MAX TONGUE WEIGHT
 DO NOT EXCEED TOWING VEHICLE RATINGS

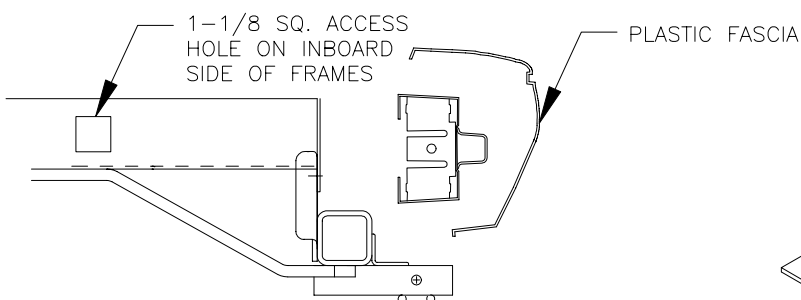

HITCH SHOWN IN PROPER POSITION

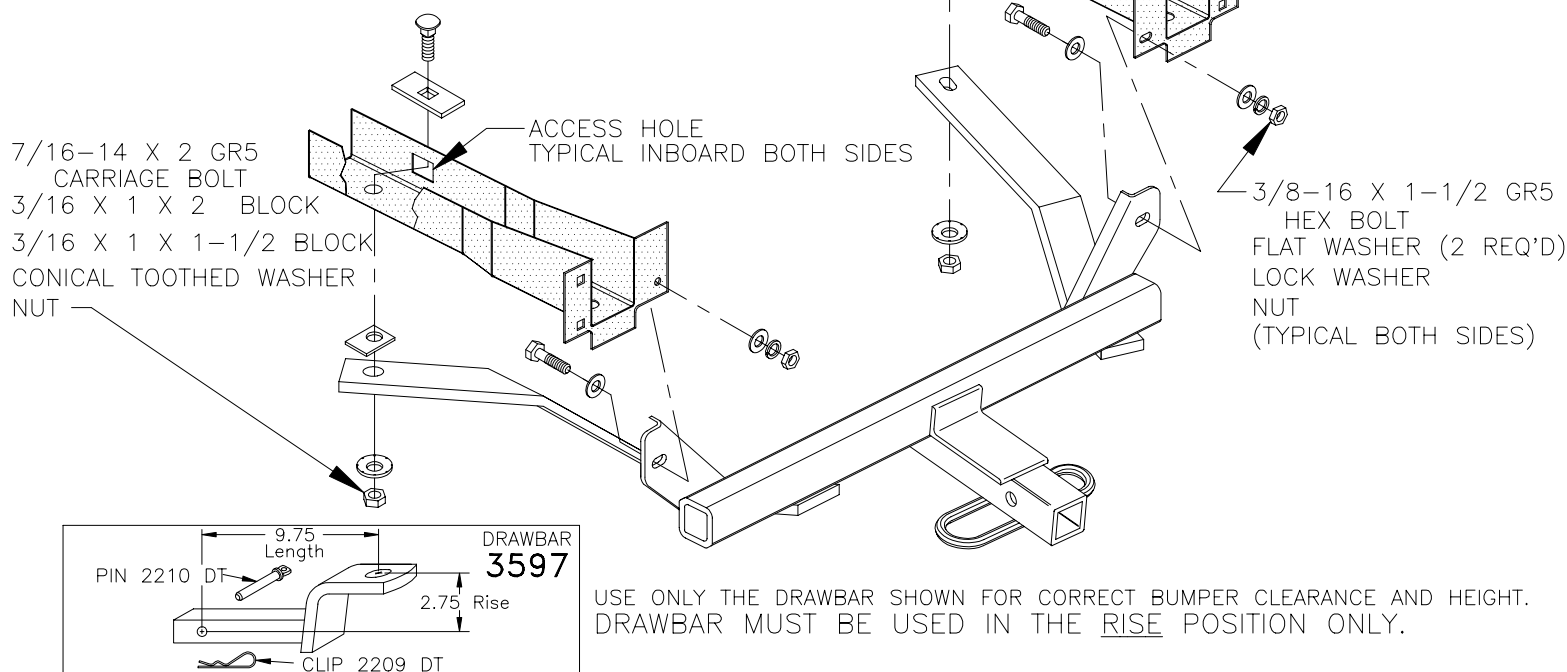

USE ONLY THE DRAWBAR SHOWN FOR CORRECT BUMPER CLEARANCE AND HEIGHT. DRAWBAR MUST BE USED IN THE RISE POSITION ONLY.

- REMOVE TWO (2) 8mm BOLTS (13mm WRENCH) FROM INBOARD LOWER CORNERS WHICH ATTACH BUMPER BRACKETS TO VEHICLE FRAME. ENLARGE HOLES WITH 7/16 DRILL BIT IF NEEDED.
- TEMPORARILY LOWER EXHAUST SYSTEM (2) PLACES (13mm WRENCH).
- BEND THE HEAT SHIELD (DRIVERS SIDE) TO GET TO SQUARE ACCESS HOLE ON THE INBOARD SIDE OF THE FRAME AND INSTALL THE 7/16 FASTENER AND BLOCK. BEND HEAT SHIELD BACK INTO POSITION.
- RAISE HITCH INTO POSITION (MAKE SURE THE DRIVER SIDE ARM GOES OVER THE TOP TO THE MUFFLER HANGER), LINE UP HOLES IN HITCH UPRIGHT BRACKETS WITH HOLES IN FORWARD SURFACE OF VEHICLE. INSTALL 3/8 FASTENERS THROUGH VALANCE PANEL AND HITCH UPRIGHT BRACKET, EACH SIDE, AS SHOWN.
- INSTALL 7/16 FASTENERS THROUGH SQUARE ACCESS HOLE ON INBOARD SIDE OF FRAME (ON PASSENGER SIDE) AS SHOWN ABOVE.
NOTE: BEND THE HEAT SHIELD TO ALLOW THE SIDE ARM ACCESS TO THE PROPER LOCATION .
NOTE: DRIVER SIDE GETS THE BLOCK AS A SPACER ON THE HEAT SHIELD.
NOTE: USE OF U-SHAPED BLOCK ON PASSENGER SIDE ONLY.
- REATTACH EXHAUST SYSTEM.

TIGHTEN 3/8 GR5 FASTENERS TO 31 LB-FT.
 TIGHTEN 7/16 GR5 FASTENERS TO 50 LB.-FT.

THIS PRODUCT COMPLIES WITH SAFETY SPECIFICATIONS AND REQUIREMENTS FOR CONNECTING DEVICES AND TOWING SYSTEMS OF THE STATE OF NEW YORK AND V.E.S.C. REGULATION V-5.

APPROX WEIGHT (LB.)	FASTENER KIT
33	F24733

NOTE: Check hitch frequently, making sure all fasteners and ball are properly tightened. If hitch is removed, plug all holes in trunk pan or other body panels to prevent entry of water and exhaust fumes. A hitch or ball which has been damaged should be removed and replaced. Observe safety precautions when working beneath vehicle and wear eye protection. Follow car maker's specs for maximum trailer weight and tongue weight. Do not cut access or attachment holes with a torch.

TOWING PRODUCTS
 Plymouth, Michigan