

SPORT FRAME[®]**INSTALLATION INSTRUCTIONS**

VEHICLE

HITCH NO.

CHEVROLET MONTE CARLO
CHEVROLET LUMINA SEDAN

24628

EQUIPMENT REQUIRED: HACKSAW

DRILL BITS: 1/2

WRENCHES: (TIGHTEN ALL FASTENERS WITH TORQUE WRENCH) 13mm, 3/4

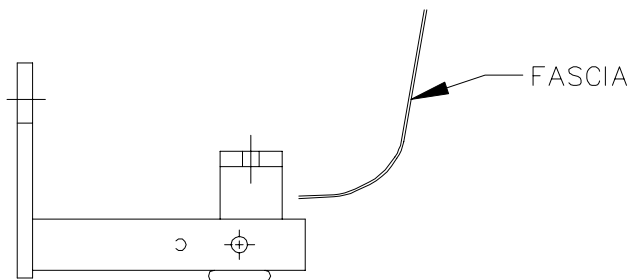
2000 LB MAX GROSS TRAILER WT
200 LB MAX TONGUE WEIGHT
DO NOT EXCEED TOWING VEHICLE RATINGS

HITCH SHOWN IN PROPER POSITION

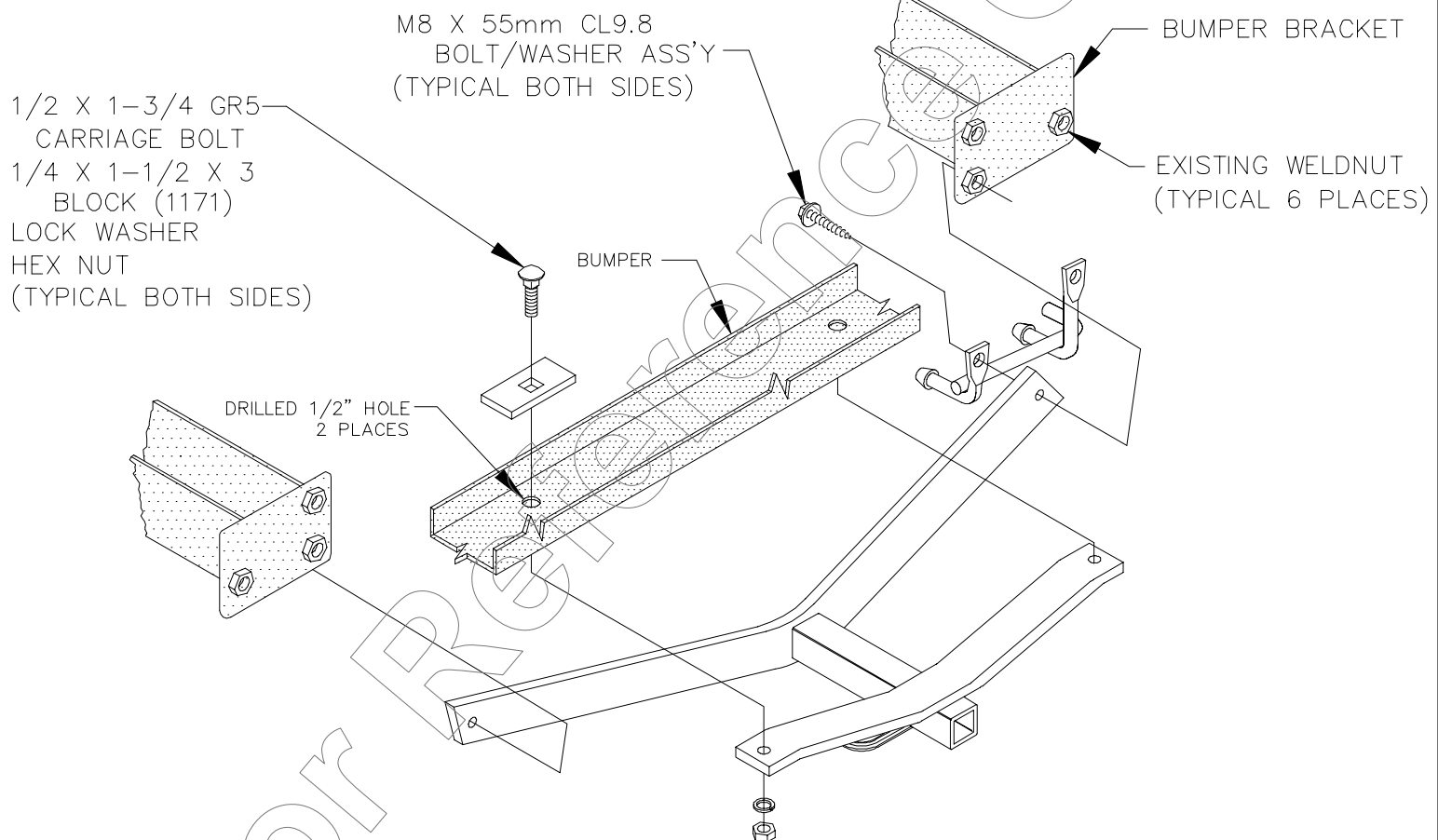

FIGURE 1

SHOWN WITH SINGLE EXHAUST SYSTEM
FOR DUAL EXHAUST SYSTEMS REPEAT
STEPS FOR BOTH SIDES

THIS PRODUCT COMPLIES WITH SAFETY SPECIFICATIONS AND REQUIREMENTS FOR CONNECTING DEVICES AND TOWING SYSTEMS OF THE STATE OF NEW YORK AND V.E.S.C. REGULATION V-5.

APPROX WEIGHT (LB.)

20

FASTENER KIT NO.

1130-946

NOTE: Check hitch frequently, making sure all fasteners and ball are properly tightened. If hitch is removed, plug all holes in trunk pan or other body panels to prevent entry of water and exhaust fumes. A hitch or ball which has been damaged should be removed and replaced. Observe safety precautions when working beneath a vehicle and wear eye protection. Follow car maker's specs for maximum trailer weight and tongue weight. Do not cut access or attachment holes with a torch.



Canton, Michigan

SPORT FRAME[®]

INSTALLATION INSTRUCTIONS

VEHICLE	HITCH NO.
CHEVROLET MONTE CARLO CHEVROLET LUMINA SEDAN	24628

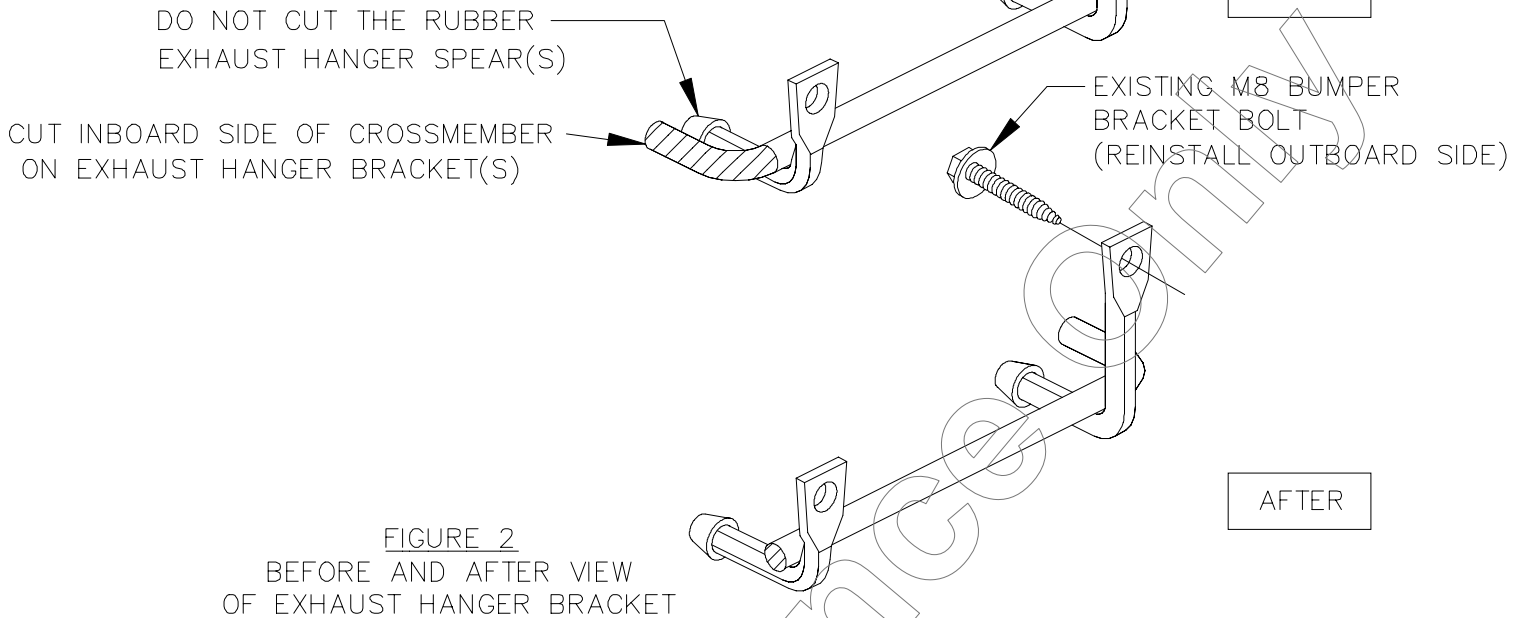

FIGURE 2
BEFORE AND AFTER VIEW
OF EXHAUST HANGER BRACKET

NOTE: FOR DUAL EXHAUST SYSTEMS REPEAT STEPS FOR BOTH SIDES.

1. LOWER THE EXHAUST SYSTEM(S) BY UNBOLTING THE M8 EXHAUST HANGER/BUMPER BRACKET BOLTS
2. DISCONNECT HANGER BRACKET(S) FROM EXHAUST SYSTEM(S), MODIFY EXHAUST HANGER BRACKET(S) AS SHOWN IN FIGURE 2 AND LOOSELY REINSTALL M8 FASTENER THRU OUT BOARD WELDNUT.
3. RAISE HITCH INTO POSITION AND LOOSELY INSTALL M8 FASTENERS PROVIDED, THRU EXHAUST HANGER, HITCH, AND BUMPER BRACKET(S), INTO THE EXISTING WELDNUT, AS SHOWN IN FIGURE 1.
4. USING HITCH AS TEMPLATE, DRILL 1/2" HOLES IN BUMPER.
5. INSTALL 1/2" FASTENERS THRU THE BLOCK (1171) AND BUMPER INTO THE HITCH WITH NUTS PROVIDED, AS SHOWN FIGURE 1.
6. REINSTALL EXHAUST SYSTEM(S) TO HANGER BRACKETS.
7. INSTALL EXHAUST HANGER FASTENERS AS SHOWN IN FIGURES 1 & 2.

TIGHTEN 1/2 GR5 FASTENERS TO 75 LB.-FT.
TIGHTEN M8 CL9.8 FASTENERS TO 25 LB.-FT.

<p>COMPLETE HITCH INCLUDES</p> <p>PIN 2210</p> <p>CLIP 2209</p> <p>3597 DRAWBAR</p>	<p>DRAWBAR REPLACEMENT KIT (INCLUDES PIN & CLIP)</p> <p>3592</p> <p>NOTE: REPLACEMENT DRAWBAR AVAILABLE ONLY IN KIT. PINS & CLIPS AVAILABLE SEPARATELY.</p>
--	--

USE ONLY THE DRAWBAR SHOWN FOR CORRECT BUMPER CLEARANCE AND HEIGHT.
DRAWBAR MUST BE USED IN THE RISE POSITION ONLY.

REMOVE DRAWBAR WHEN NOT TOWING
TO PROTECT DRAWBAR OPENING IN HITCH WHEN NOT TOWING,
INSERT COVER #2211 (PURCHASED SEPARATELY).

THIS PRODUCT COMPLIES WITH SAFETY SPECIFICATIONS AND REQUIREMENTS FOR CONNECTING DEVICES AND TOWING SYSTEMS OF THE STATE OF NEW YORK AND V.E.S.C. REGULATION V-5.

APPROX WEIGHT (LB.)	FASTENER KIT NO.
---------------------	------------------

NOTE: Check hitch frequently, making sure all fasteners and ball are properly tightened. If hitch is removed, plug all holes in trunk pan or other body panels to prevent entry of water and exhaust fumes. A hitch or ball which has been damaged should be removed and replaced. Observe safety precautions when working beneath a vehicle and wear eye protection. Follow car maker's specs for maximum trailer weight and tongue weight. Do not cut access or attachment holes with a torch.

