

# BEFORE INSTALLING- OVERHEAD LIFTING DEVICE

An overhead-lifting device, such as chain falls, engine hoist, or cable come-a-long, can be used to lift the center section of the hitch in place. Lower a loop of rope or chain through the 4" hole in the truck bed floor and attach it to the latch pin in the round hitch receiver tube in the center section. Use the lifting device to raise the center section until the round hitch receiver tube that protrudes from the center section fits in the 4" hole in the truck bed floor. Maintaining upward pressure may facilitate fastening the crossmember to the center section, especially if the truck bed floor has been distorted downward from heavy use. If you use an overhead-lifting device, it should be disconnected before squaring the center section across the frame, installing the sideplates and torquing fasteners.

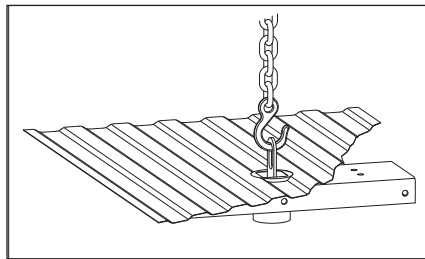

## WARNING

Most trucks have FUEL LINES and/or BRAKE LINES and/or ELECTRICAL WIRES located along the frame rails where B&W Turnover Ball hitches install. Carefully examine the location of fuel lines, brake lines and electrical wires BEFORE INSTALLATION. Be certain you will not damage fuel lines, brake lines or electrical wires when positioning hitch components, drilling holes, tightening fasteners, and lifting and lowering the truck bed. The fuel tank vent, located on top of the gas tank, can be easily damaged during the installation of the hitch components. Care must be taken when positioning the front crossmember and center section components.

## WARNING

**The Ball can not be stored in the socket of this hitch.**

**The 4" Toyota Hitch Extender part # 4585 will work with this model Turnover Ball.**

**At this time no other accessory including the Companion will work with this model of Turnover Ball due to design changes.**

## WARNING

On Short bed trucks, BEFORE INSTALLING THIS HITCH, check for adequate turning clearance between the front of all of your trailers and the truck cab.

## Important Information

Because of space restraints the 2007 Toyota Tundra mounting kit contains components that have not been seen in any previous Turnoverball kits. **For this reason it will not be possible to store the ball in the inverted position. It also makes the 4" hole location very critical. It is important to read the complete instruction sheet before beginning the installation.**

# INSTALLATION INSTRUCTIONS

**BALL LOCATION:** 2007 Toyota Tundra 4" hole location 42 3/8" All beds.

## STEP 1 - MARKING AND CUTTING 4 INCH HOLE IN TRUCK BED

Begin by measuring for the correct hole location in the truck bed floor. Measure from the tail gate end of the truck bed floor by hooking a tape measure over the end of the truck box and mark the floor at 42 3/8". Next find the center point between the wheel wells, where these marks intersect with the first measurement will be the center point of your four inch hole. This Location is critical to the correct installation of the B&W Turnover Ball so measure, mark and saw carefully. Make a four inch hole at this location. B&W recommends using a four inch hole saw, however the hole can be cut by other means. If your truck has a spray-in bed liner you will need to take into account when you are measuring to add the thickness of the applied liner that has been sprayed over the end of the bed. If your truck has a Drop-in plastic bed liner, you may saw through both, but it is more difficult to accurately locate the midpoint between the fender wheel wells, and to be sure that the bed liner does not move when sawing the hole. Once you have the four inch hole in the bed use a deburring tool or a die grinder and carefully remove the burr from the under side of the bed around the hole.

## STEP 2 - Pre-Installation

Remove the two bolts holding the exhaust heat shield using a 10mm wrench. Locate the fuel pump control on the inside of the drivers side frame. Using a 12mm wrench remove the two nuts on the outside of the frame that are holding it in place (Fig. 1). Retain the nuts to be replaced later. Next locate the fuel vapor canister box mounted just under the front bed crossmember on the driver's side of the truck. Remove the nut holding the wiring bracket to the back of the box (Fig. 2). This will be relocated later. On the top of the passenger side frame rail locate the plastic wiring bracket and remove from top of frame. Place the wiring harness inside the frame rail. It will be held in place with the sideplate. Locate the tail pipe hanger toward the back of the tail pipe and slide the rubber hanger off of the tubing that is welded to the pipe (Fig. 3).

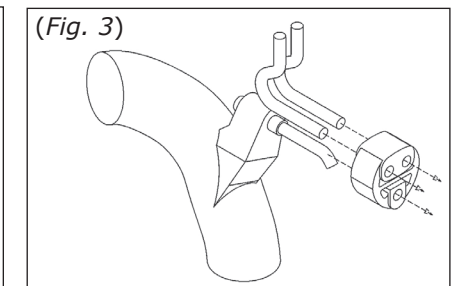
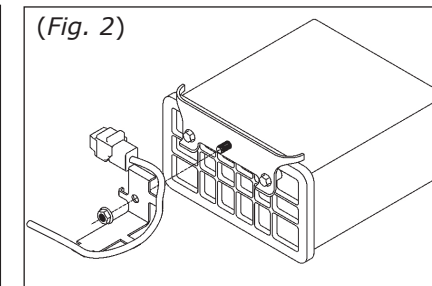
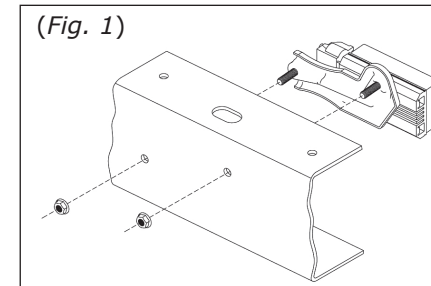

## STEP 3 - Cross Member Installation

There are four crossmember parts included in the kit. Two channel type and two flat type. Place one of the channel crossmembers between the top of the frame and the under side of the bed. Make sure that both flanges of the channel are facing down and the notches at each end are toward the front of the truck. Once the crossmember has span both frame rails it can be rotated down and slide forward. Next install a flat crossmember in the same manner and slide it forward. Install the other two in the same manner except with the notches facing the rear of the truck. Slide them toward the rear as far as possible.

## STEP 4 - Center Section Installation

Install 1/2" x 2" carriage bolts through the center four holes of the front crossmembers. The threaded part of the bolts should face toward the rear of the truck with the square part of the bolts fitting into the square holes in the crossmembers. With the latch pin on the driver's side lift the center section up on to the bolts and hand tighten with flat washers, lock washers, and nuts. Now the center section and the front crossmember can slide forward. This will allow the 4" round top of the center to be placed into the hole in the truck bed. A lifting device as describe previously will help if available. With the top of the center section placed through the hole in the bed slide the rear crossmembers against the rear of the center and install carriage bolts in the same manner as before. All bolts must be left loose at this point for sideplate installation.

## STEP 5 - Side Plate Installation

Using the diagram at the right determine the driver and passenger side sideplate. Place the appropriate side plate on the inside of the frame with the small flanges fitting between the crossmembers. The top long flange will sit on the upper leg of the frame with the bottom long flange sitting on the top of lower leg of the frame. With each sideplate in place insert carriage bolts through the square holes in the crossmembers and through the small flanges on the sideplates. Place a flat washer, lock washer and nut on the bolts and leave loose at this time. Next place a 5/8" x 1-1/2" bolt with a flat washer and frame spacer (see diagram at right) through the oval holes in the frame. Two will go through the bottom frame leg using a 1/4" frame spacer and two in the top frame leg using a 1/8" frame spacer. After passing through the frame and sideplate install a lock washer and nut.

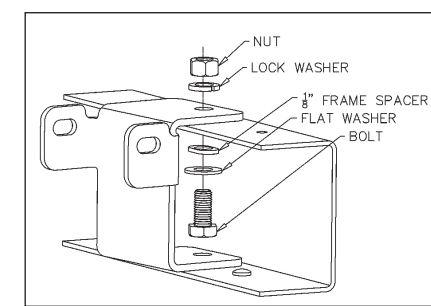
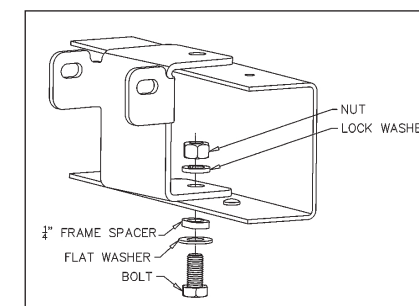
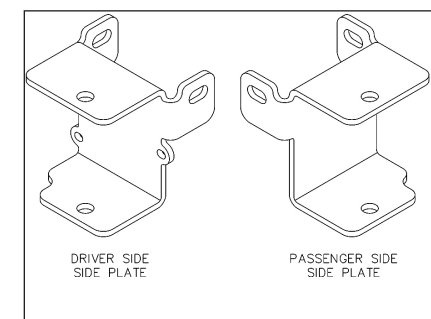

## STEP 6 - Tighten Hardware

Make sure that the hitch crossmembers are space equally from side to side and front to rear. Make sure the center section is tight against the under side of the truck bed and tighten the eight 1/2" carriage bolts holding the center section to the crossmembers to 80 ft. lbs. Next tighten the four 1/2" carriage bolts holding the crossmembers to the side plates to 80 ft. lbs. Make sure that the frame spacers are completely into the oval holes in the frame and tighten the four 5/8" bolts holding the sideplates to the frame, torque to 100 ft. lbs.

## STEP 10 - INSTALL LATCH PIN RELEASE HANDLE

**WARNING: LATCH PIN WILL NOT FUNCTION PROPERLY IF HANDLE IS NOT INSTALLED CORRECTLY.**  
Install the handle from underneath the truck by inserting it through the slot in the end of the center section toward the driver's side rear tire as shown. Attach the handle to the latch pin as shown with the handle on the "cab side" of the square tab welded to the pin. The head of the bolt must be on the handle side, and the lock nut must be on the tab side. The tab is welded to the pin in an offset position so that the handle will be lined up over the center of the pin. If the handle is fastened to the other side of the tab, the handle will not function properly. When installed correctly the latch pin may be disengaged from the ball by pulling on the handle from the driver's side wheel well and rotating the handle clockwise.

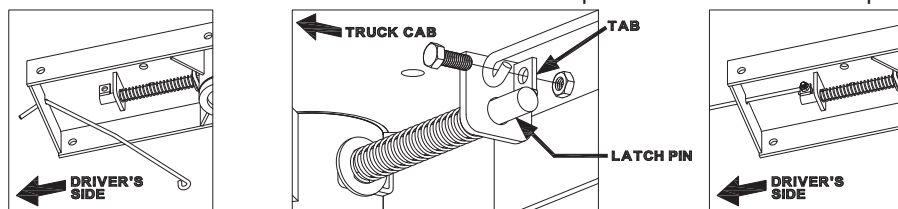

## STEP 8 - Reinstall Components

Re-attach the fuel pump control to the driver's side frame that was removed earlier. (If air springs are being used move the relay to the inside of the side plate and mount in the holes supplied). Using the relocation bracket, 5/16" carriage bolt and 5/16" flange nut supplied, reattach the wiring bracket to the fuel canister. (See diagram at right)

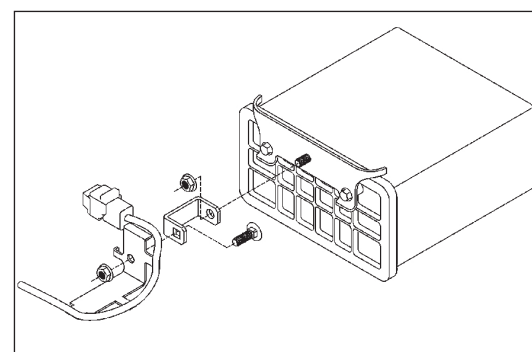

Some trucks may need the exhaust pipe lowered slightly. If the tail pipe has less than 1/4" clearance between it and the hitch use the lowering bracket that is supplied in the kit. Slide it through the lower slot in the rubber hanger and turn downward. This will allow the tube on the tailpipe to slide through the bracket and lower the pipe slightly to give clearance for the hitch. (See diagrams below)

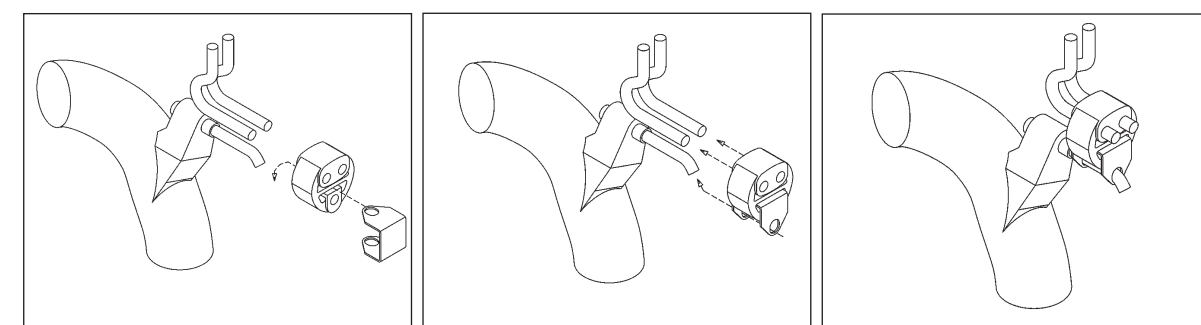

## STEP 9 - Install Safety Chain U-Bolts

To install the safety chain U-bolts it is necessary to drill four 1/2" holes through the truck bed floor. Drill the holes from beneath the truck, through the two holes located on each side and closest to the round receiver tube in the center section. This will locate the safety chain U-bolt in the lowest point of the floor corrugation. After you drill the four holes clean the burrs from around the holes in the top of the bed then drop a U-bolt through each pair of holes. Place a spring and lock nut on each of the four legs. Tighten the nuts until flush with the bottom of the U-bolts.

## STEP 10 - Re-engage Latch Pin Handle

Retract the latch pin by pulling the handle all the way out until it stops and then rotate it clockwise. Place the Turnover Ball in the hitch receiver. Engage the latch pin by rotating the handle counterclockwise. Be certain the latch pin passes through the holes in the Turnover Ball and fully engages through the hitch receiver. Remove and grease the square base of the Turnover Ball.



## B&W Trailer Hitches

1216 HWY 224 / PO Box 186  
Humboldt, KS 66748  
P:620.473.3664  
F:620.473.3766

**NOTE: We recommend reading instructions before beginning the installation.**

## Turnover Ball™ Gooseneck Hitch Installation Instructions

### Model 1257R

**Toyota Tundra (2007 - 2010)**

*The Ball can not be stored in the socket of this hitch.*

*4" Toyota Hitch Extender part # 4585 will work with this model Turnover Ball.*

*At this time no other accessory including the Companion will work with this model of Turnover Ball due to design changes.*

Call or Email us for Installation Support  
**800.248.6564** [hitches@turnoverball.com](mailto:hitches@turnoverball.com)

[www.turnoverball.com](http://www.turnoverball.com)

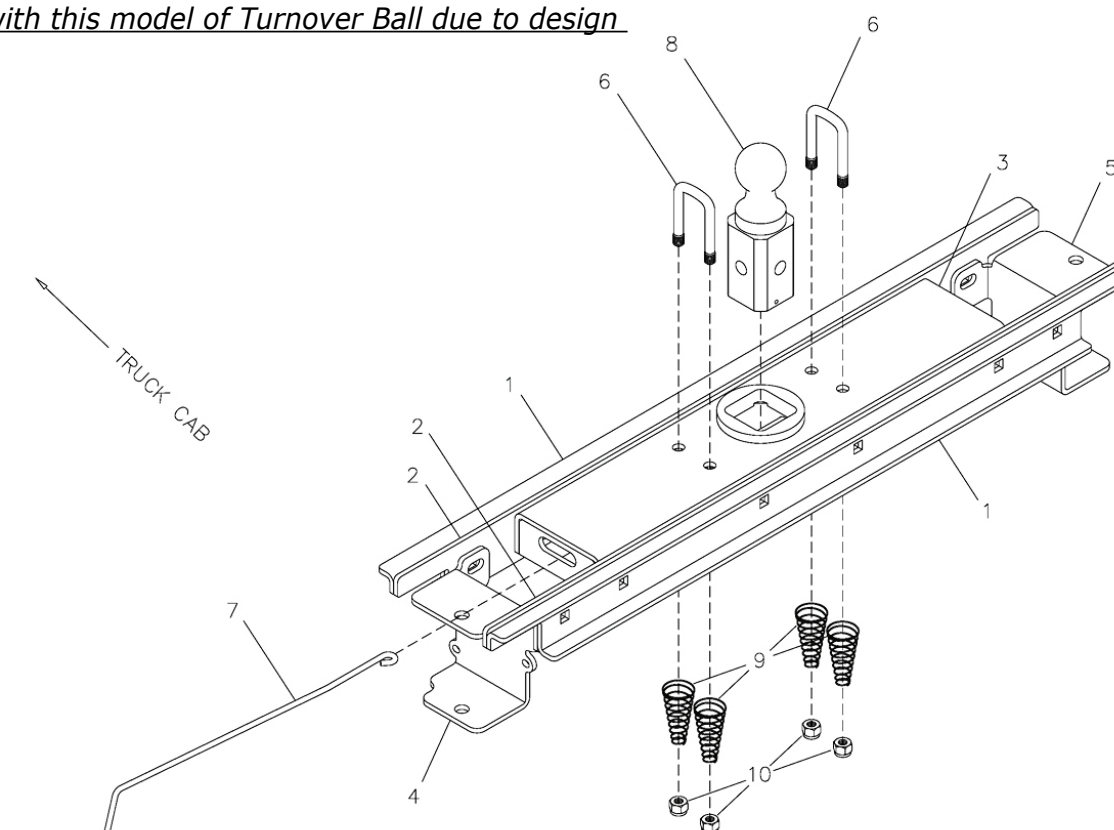

### Parts List

- 1 - Crossmembers
- 2 - Crossmember Brace
- 3 - Center Section
- 4 - Driver's Side Sideplate
- 5 - Passenger's Side Sideplate
- 6 - Safety Chain U-Bolts
- 7 - Latch Pin Handle
- 8 - Turnover Ball
- 9 - Springs
- 10 - 1/2" Lock nuts

### Hardware Kit

- 4 ea. - 5/8" cap screws
- 4 ea. - 5/8" finish nuts
- 4 ea. - 5/8" flat washers
- 4 ea. - 5/8" lock washers
- 12 ea. - 1/2" carriage bolts
- 12 ea. - 1/2" finish nuts
- 12 ea. - 1/2" lock washers
- 12 ea. - 1/2" flat washers
- 1 ea. - 5/16" carriage bolt
- 1 ea. - 5/16" flange nut

### Safety Chain Kit

- 2 ea. - 1/2" U-bolts
- 4 ea. - 1/2" lock nuts
- 4 ea. - springs
- 1 ea. - 3/8"x3/4" Bolt
- 1 ea. - 3/8" Lock nut